

NOVEMBER
2007

MARINE ASSESSMENT

FIBRALINK NEW CABLE LAY

[Prepared for Fibralink Jamaica Limited]

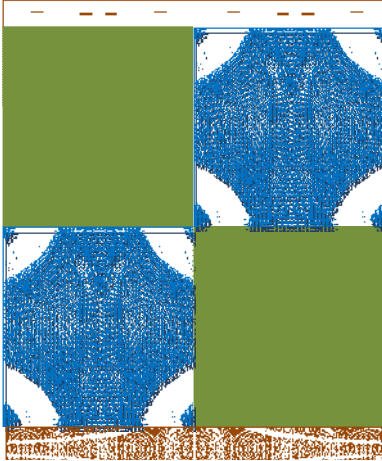

CONRAD DOUGLAS & ASSOCIATES LIMITED

14 Carvalho Drive
Kingston 10
Jamaica W.I.

Telephone: 929-0023/0025/8824

Email: estech@infochan.com;

cdaestech@hotmail.com; conraddouglasnassociatesltd@gmail.com

MARINE ASSESSMENT

Fibralink New Cable Lay

September 2007

Prepared for:

Fibralink Jamaica Limited

Table of Contents

	Page Number
Table of Contents	i
List of Tables	iv
List of Figures	v
List of Plates	vii
List of Appendices	viii
1 Executive Summary	1-1
1.1 Introduction.....	1-1
1.2 Conclusion	1-3
2 Project Description.....	2-1
2.1 Introduction.....	2-1
2.2 Background.....	2-2
2.2.1 <i>Regional Cable History</i>	2-3
2.3 The Proposed Project	2-4
2.3.1 <i>The Cable</i>	2-4
2.3.2 <i>Proposed Implementation</i>	2-7
2.3.3 <i>Landing Sites</i>	2-10
2.3.4 <i>Marine Ducts and Near-Shore Manhole (NSM) Design and Construction</i> <i>Methodology</i>	2-20
2.3.5 <i>Recommended Fibre-Optic Cable Installation Techniques</i>	2-28
2.3.6 <i>Cable Repair Techniques</i>	2-35
2.3.7 <i>Waste Streams</i>	2-38
3 Legislative and Regulatory Framework.....	3-1
3.1 Introduction.....	3-1
3.2 National Policies	3-2
3.3 Applicable Legislation	3-2
3.3.1 <i>The Natural Resources Conservation Authority Act, 1991</i>	3-2
3.3.2 <i>The Wildlife Protection Act, 1945</i>	3-6
3.3.3 <i>The Beach Control Act, 1956</i>	3-6
3.3.4 <i>The Town and Country Planning Act</i>	3-7
3.3.5 <i>The Public Health Act, 1985</i>	3-9
3.3.6 <i>The Jamaica National Heritage Trust Act, 1985</i>	3-10
3.3.7 <i>The National Solid Waste Management Authority Act, 2001</i>	3-10
3.3.8 <i>Draft National Building Code for Jamaica, 2007</i>	3-10
3.3.9 <i>St. Thomas Parish Development Plan,</i>	3-11
3.4 International Policy.....	3-11
3.4.1 <i>Agenda 21</i>	3-11
4 Analysis of Alternatives.....	4-1

4.1	Introduction.....	4-1
4.2	No-Action Alternative	4-1
4.3	Landing Site Alternatives	4-1
4.3.1	<i>Bull Bay, St Andrew Alternatives</i>	4-1
4.3.2	<i>Prospect - Morant Point, St Thomas Alternatives</i>	4-2
4.4	Technology Alternatives.....	4-3
4.4.1	<i>Radio</i>	4-4
4.4.2	<i>Telephony</i>	4-4
4.4.3	<i>Satellite Data Transmission</i>	4-5
5	Description of the Environment.....	5-1
5.1	Physical Environment.....	5-1
5.1.1	<i>Meteorology</i>	5-1
5.1.2	<i>Hydro- and Geophysical Environment</i>	5-4
5.2	Hazard and Risk Assessment.....	5-7
5.2.1	<i>Offshore Cable Operations</i>	5-7
5.2.2	<i>Onshore Cable Operations</i>	5-8
5.2.3	<i>Seismic Vulnerability</i>	5-9
5.2.4	<i>Hurricane Vulnerability</i>	5-16
5.2.5	<i>Flooding Potential</i>	5-18
5.2.6	<i>Overall Assessment of Natural Hazard Vulnerability of Sites</i>	5-19
5.3	Biological Environment.....	5-20
5.3.1	<i>Bull Bay, St. Andrew</i>	5-20
5.3.2	<i>Prospect, St. Thomas</i>	5-23
6	Socio-Cultural Environmental	6-1
6.1	Introduction.....	6-1
6.2	Methodology.....	6-1
6.3	Survey Findings	6-3
6.3.1	<i>Segment 1: Bull Bay Proposed Landing Site</i>	6-3
6.3.2	<i>Segment 2: Prospect Proposed Landing Site</i>	6-6
6.3.3	<i>Impact on the Marine Community (Fishermen, Bathers etc.)</i>	6-9
6.3.4	<i>Interpretation</i>	6-11
7	Determination of the Potential Impacts of the Proposed Project.....	7-1
7.1	Introduction.....	7-1
7.2	Potential Impacts [Physical, Biological, Socio-Cultural]	7-4
7.2.1	<i>Aesthetics</i>	7-4
7.2.2	<i>Water Quality/Surface Water Hydrology and Groundwater</i>	7-4
7.2.3	<i>Air Quality</i>	7-4
7.2.4	<i>Noise & Vibration</i>	7-5
7.2.5	<i>Wildlife & Vegetation Resources</i>	7-5
7.2.6	<i>Employment & Socio-Economic Impacts</i>	7-6
7.2.7	<i>Solid Waste</i>	7-7
7.2.8	<i>Occupational Health and Safety</i>	7-7
7.3	Impact Identification and Mitigation Matrices	7-8

8 Environmental Management and Monitoring Plan..... 8-1

8.1 Introduction..... 8-1

8.2 Pre-Construction Phase..... 8-1

8.3 Construction Phase..... 8-2

List of Tables

	Page Number
Table 2-1: Potential Cable Crossings.....	2-3
Table 2-2: Typical Shore End Equipment List	2-33
Table 2-3: Percentage of Failure Causes for 380 Reported Cable Faults	2-35
Table 3-1: Summary of the Applicable Legislation and the Responsible Agencies.....	3-1
Table 5-1: 10% Probability Exceedance in any 50 year Period of Three Earthquake Parameters for the Proposed Landing Sites	5-11
Table 5-2: Mercalli Scale.....	5-11
Table 5-3: Kingston Central Port Wind Results (knots): Maximum Likelihood Estimates and Upper Prediction Limits for Various Return Periods (1 minute sustained wind at 10 meters above ground).....	5-16
Table 5-4: Kingston Central Port Storm Surge Results (meters): Maximum Likelihood Estimates and Upper Prediction Limits for Various Return Periods.....	5-17
Table 5-5: Kingston Central Port Wave Height Results (untransformed deep water significant wave height in meters): Maximum Likelihood Estimates and Upper Prediction Limits for Various Return Periods	5-17
Table 6-1: Enumeration Districts Surveyed.....	6-1
Table 6-2: Age and Years of Residency within each Community/ED	6-4
Table 6-3: Age and Years of Residency within each Community/ED	6-7
Table 7-1: Potential Sources of Environmental Impacts	7-2
Table 7-2: Impact Identification Table - Bull Bay, St. Andrew	7-8
Table 7-3: Impact Identification Table - Prospect, St. Thomas	7-9
Table 7-4: Impact Mitigation Table – Prospect & Bull Bay.....	7-10

List of Figures

	Page Number
Figure 2-1: Proposed and Existing Regional Fibre-Optic Cable Connections	2-3
Figure 2-2: Fibre-Optic Cable Cross-Section	2-5
Figure 2-3: Typical Cross-section of a single armoured sub-marine fibre optic cable (Not to Scale).....	2-6
Figure 2-4: Articulated Piping to Protect the Submarine Cable	2-7
Figure 2-5: Typical Equipment Building Layout – Plan and Front End Elevations.....	2-11
Figure 2-6: Typical Equipment Building Layout – Side End Elevations	2-12
Figure 2-7: Typical Equipment Building Structural Design – Key Structural Design Areas Highlighted	2-13
Figure 2-8; Typical Equipment Building Structural Design – Detailed overview of Key Structural Design Areas.....	2-14
Figure 2-9: Shoreline Baseline.....	2-15
Figure 2-10: New Bull Bay Landing Site [Google Aerial Imagery]	2-16
Figure 2-11: New Bull Bay Landing Approach.....	2-17
Figure 2-12: Shoreline at Prospect.....	2-18
Figure 2-13: Prospect Landing Site [Google Aerial Imagery].....	2-19
Figure 2-14: Prospect Landing Approach.....	2-19
Figure 2-15: Proposed Cable Station Sites	2-20
Figure 2-16: Trencher in Operation	2-22
Figure 2-17: Typical Manhole Detail	2-24
Figure 2-18: Trenching Details.....	2-25
Figure 2-19: Bull Bay - Location of Manhole in Proximity to roads and buildings.....	2-25
Figure 2-20: Prospect - Proposed Manhole Location at Ocean View Close	2-26
Figure 2-21: Back Haul - Trench Cross-Section.....	2-27
Figure 2-22: Back Haul - Hand Hole Section.....	2-27
Figure 2-23: Reinstated Roadways	2-28
Figure 2-24: Typical Deck Layout.....	2-30
Figure 5-1: Average Annual Rainfall for the Palisadoes, St. Andrew, 2000-2006	5-2
Figure 5-2: Average Annual Rainfall for Morant Point, St. Thomas, 2000-2006	5-2

Figure 5-3: Average Wind Speed per Year along the South-East coast of Jamaica, 2000-2006 5-3

Figure 5-4: Hydrostratigraphic Map showing the two sites: Bull Bay and Prospect..... 5-6

Figure 5-5: Tectonic Plates in the Caribbean region 5-9

Figure 5-6: Epicentres of Earthquakes Occurring Between 1998 and 2001 In The Vicinity Of Jamaica..... 5-10

Figure 5-7: Horizontal Ground Acceleration in Jamaica 5-13

Figure 5-8: Maximum Mercalli Intensity in Jamaica 5-13

Figure 5-9: Horizontal Ground Velocity in Jamaica..... 5-14

Figure 5-10: Land Slide Susceptibility Map for Bull Bay, St. Andrew Site 5-15

Figure 5-11 Extent of 2001 Flooding in Bull Bay 5-19

Figure 5-12: Substrates Observed / Interpreted Along Proposed Alignment [Base Image 1991 Aerial Image – Survey Dept.] 5-23

Figure 6-1: Enumeration Districts Surveyed for Bull Bay Landing Site, St. Andrew..... 6-2

Figure 6-2: Enumeration Districts Surveyed for Prospect Landing Site, St. Andrew 6-3

Figure 6-3: Perceived Impact of Fibre Optic Cables 6-5

Figure 6-4: Technology in Home..... 6-6

Figure 6-5: Perceived Impact of Fibre Optic Cables 6-8

Figure 6-6: Technology in Home..... 6-9

List of Plates

	Page Number
Plate 2-1: Horizontal Direction Drill - Ditch Witch JT2720	2-21
Plate 2-2: Illustration of Installation from Ship with a Sheave.....	2-30
Plate 2-3: Illustration of Installation with a Winch on the Shore; Buoyed Cable on the Right.	2-31
Plate 2-4: Illustration of Installation Using a Landing Craft	2-32
Plate 5-1: Beach character [Note: retaining wall approximately 30 m from shoreline]	5-20
Plate 5-2: View from the shoreline (Looking northwest)	5-21
Plate 5-3: New Little Copa Club Parking Lot.....	5-22
Plate 5-4: Vegetation at the New Little Copa Club	5-22
Plate 8-1: Proposed Alignment in Waters <30m in Depth	XII
Plate 8-2: Substrate / Benthic Lifeforms Observed Along Proposed Alignment at Prospect, St. Thomas - Waypoints 5 & 7.....	XIII
Plate 8-3: Identification of Benthic Lifeforms Observed along Proposed Alignment – Encrusting and Plating Corals.....	XIV
Plate 8-4: Identification of Benthic Lifeforms Observed along Proposed Alignment – Plating and Boulder Corals	XV
Plate 8-5: Mobile Lifeform Observed along Proposed Alignment.....	XVI
Plate 8-6: Identification of Benthic Lifeforms Observed along the Proposed Alignment - Waypoint 2.....	XVII
Plate 8-7: Identification of Benthic Lifeforms Observed along the Proposed Alignment - Waypoint 8 & 9.....	XVIII

List of Appendices

	Page Number
Appendix I: Approved Marine Assessment Scope of Detail	I
Appendix II: Fibralink Licence & Signature Page Scan.....	VIII
Appendix III: Project Team	X
Appendix IV: Marine Photo-Inventory.....	XII

EXECUTIVE SUMMARY

1 Executive Summary

1.1 Introduction

Fibralink Jamaica Limited is planning to expand their existing submarine fibre-optic network to maintain network diversity and reliability, by constructing a sub-sea fibre cable connection between Boca Raton, Florida to Columbia via Jamaica.

This will provide a high-capacity fibre-optic connection between the United States (US) and Jamaica, and Jamaica and South America. The project will see an efficient communications system being put in place that improves on quality and reliability. The project is designed to minimize network contingencies such as potential data transmission disruptions due to network cuts and outages, and natural disasters such as hurricanes, through a redundant network.

The project will provide an unrepeated spur to Jamaica and improve the existing physical diversity; the landing areas proposed will be east of the existing AT&T Bull Bay landing utilized by FibrLink on the south coast. Under FibrLink's license, physical diversity is required from its existing AT&T Bull Bay landing. Additionally, to provide synergies between Columbus Networks (Bahamas) and Flow Jamaica, the new landing at Prospect is in keeping with plans for a new Flow hub.

This proposed fibre-optic connection will improve and provide additional data transmission capability, increased suppliers and reduced costs, and supply the increasing demand for electronic communications (phone, facsimile, email, Internet) to the eastern end of the island.

The projects purpose is to employ marine cable installation technology to install a submarine fibre-optic cable at the following proposed landing sites:

- Bull Bay, St. Andrew, and
- Prospect, St. Thomas

The project will use state-of-the-art cable installation technology to provide for the maximum possible integrity and safety of the installed cable. The proposed work covered in this Marine Assessment involves:

- Explanations of the technology, routing and process of deployment of the cable
- The environmental setting and baseline for the proposed submarine cable expansion included studies, analyses and assessments on:
 - Cable type, cable laying methods
 - Solid and hazardous waste management practice
 - Routing of cables and associated risks of proposed actions
 - Analysis of Alternatives
 - Impact identification
 - Impact mitigation
 - Structural integrity testing of cable.

The potential negative environmental impacts of this study have been thoroughly addressed and our findings indicate that those potential impacts identified can be considered negligible and of short duration. These potentially negative impacts have been identified mainly during the construction phase of the project and with good project management will be sufficiently mitigated.

No new or unfamiliar major negative impacts or risks were identified. Additionally, several potentially beneficial impacts have been identified that can be realized from the implementation of this project.

The potential impacts identified for the pre-construction, construction and operating phases of the proposed project include:

Negative

- Minimal suspended solids during cable laying
- Minimal noise and vibration during construction
- Minimal aesthetics and transient change of land and marine use

Positive

- Improved broadband access by commissioning new connections

- Potential vast increase in investment revenue and job creation due to improvements in the telecommunications industry from this project.
- No loss of biodiversity
- No loss of archaeological and historical heritage resources
- Improvement in construction methods through Horizontal Directional Drilling to minimize the impact to coastal zone at landing site. This technology is a significant improvement on trenching, previously practiced.

Any negative impacts identified will be effectively mitigated using traditional and state of the art methods, as necessary, such as the use of the Horizontal Directional Drill and curbside trencher.

Several government agencies were contacted as well as various public interests throughout the Marine Assessment process. This was done to present all parties with information on the project to determine areas of potential conflict, and to encourage open dialogue on this very important development project. Further, Fibralink has promised to provide the appropriate authorities with As-Laid positions and charts for notification to the appropriate mapping agencies in the island.

An environmental management plan will be incorporated as well as a monitoring protocol for all aspects from startup to operation.

1.2 Conclusion

The proposed expansion of the broadband network for Jamaica is planned to take place against a background of improvements in the quality of broadband connection, increases in connectivity in meeting the demand, decreases in cost for access to all, and the lessening of disruption due to accidents or natural disasters.

The potential impacts identified if realized will be mitigated using proven technologies. No new or unfamiliar environmental impacts or risks have been identified with the proposed project.

The proposed project represents a continuance of the large investment in telecommunications in Jamaica and bears the potential for enormous macro and micro economic growth and development as well as social benefits to Jamaica.

PROJECT DESCRIPTION

2 Project Description

2.1 Introduction

The installation of fibre optics is the preferred method of carrying voice, video, and data communications. Its superior information-carrying capacity enables the use of applications that require large amounts of bandwidth.

Fibre-optic cable allows for optimization of transmission equipment because it lacks the delay found in satellite connections. Further, unlike satellite communications, fibre-optic cables are insensitive to electromagnetic and/or atmospheric interference and offer a secure link because of their relative immunity to eavesdropping.

To maintain network diversity and reliability, Columbus Networks through its Jamaican affiliate Fibralink Jamaica Limited will be constructing a sub-sea fibre cable connecting Boca Raton, Florida with Jamaica and Columbia.

To maintain an unrepeated spur to Jamaica and physical diversity, two new landing sites are envisioned. The landing area in Jamaica will be east of the existing AT&T Bull Bay landing utilized by FibrALink on the south coast. Under FibrALink's license, physical diversity is required from its existing AT&T Bull Bay landing. Additionally, to provide synergies between Columbus Networks and Flow Jamaica, the new landing will be sited in a region planned for a Flow hub. Flow Jamaica, a subsidiary of Fibralink is the commercial supplier of data, voice and video communications. Flow has identified Morant Bay as the most appropriate area for construction of a hub and cable landing.

The Morant Point landing will be connected to FibrALink at the AT&T Bull Bay facility via an unrepeated festoon. For diversity reasons, there will be a new landing site east of the existing AT&T Bull Bay landing. This second Bull Bay landing will be connected to FibrALink via a newly constructed underground duct system.

2.2 Background

FibraLink Jamaica Limited is a recently incorporated Jamaican company established with the expressed purpose of building, owning and operating a sub-marine fibre-optic network to provide broadband communication linkages for Jamaica to the rest of the world.

Following on the significant loss of broadband service to the island during Hurricane Ivan in September of 2004, the need for additional and redundant fibre optic linkages to the island was realized.

Pursuant to Section 13 and Section 78 of the Telecommunications Act, 2000, a licence for the construction and operation of a Submarine Fibre Optic Cable Network was granted to FibraLink Jamaica Limited on December 20, 2004 by the Minister of Commerce, Science and Technology, the Honourable Phillip Paulwell. The licence stipulates that:

In granting a licence to FibraLink Jamaica, the Office of Utility Regulations (OUR) required that all single points of failure be eliminated from the network. The first installation of landing points in Jamaica was accomplished in 2006, namely:

- Bull Bay – St. Thomas,
- Ocho Rios – St. Ann, and
- Montego Bay – St. James.

Figure 2-1 below shows the proposed routing and terrestrial connections of the proposed redundant link to the network.



Figure 2-1: Proposed and Existing Regional Fibre-Optic Cable Connections

2.2.1 Regional Cable History

Many submarine cables are installed throughout the Caribbean Region including the Bahamas and Jamaica (Figure 2-1). The following is a list of known active and inactive cables that may be crossed during this project. There is also the potential for a number of either scientific or military sub-marine cables throughout the area. It is not envisioned that these cables will interfere in any way with the proposed FibraLink cable connection.

Table 2-1: Potential Cable Crossings

System Name	Details
TCS-1	In Service: 1990 San Juan, Puerto Rico -- Barnquilla, Columbia -- Santo Domingo, Dominican Republic -- Kingston, Jamaica - 2,593km at 140 Mb/s KHz Maintenance Authorities: AT & T, MCI, Sprint

System Name	Details
ECFS	In-Service: Sept 1995 Maintenance Authorities: TSTT
ARCOS-1 (AMERICAS REGION CARIBBEAN RING SYSTEM)	Phase 1: In-Service: September 2001 Hollywood, USA; Nassau, Bahamas; Cat Island, Bahamas; Crooked Island, Bahamas; Puerto Plata, Dominican Republic; Punta Cana, Dominican Republic; San Juan, Puerto Rico.
Florida-Jamaica	Out-of-service: retired 1992, 1963: 29 years of Service Florida City, Florida, U.S.A. -- Kingston, Jamaica - 1,545km at 384 + 384 KHz Maintenance Authorities: AT & T, Jamaican International Telecommunications Ltd.
Canal Zone-Jamaica	Out-of-service: Retired 1998, 1963: 34 years of service Kingston, Jamaica - Fort Sherman, Panama - 1,150km at 384 + 384 KHz Maintenance Authorities: AT&T, ITT Central American Cables & Radio

2.3 The Proposed Project

FibraLink proposes to construct and operate a fibre-optic sub-marine cable network linking Boca Raton, Florida with Jamaica and Columbia and ultimately the world. Fibralink has experience with installing fibre-optic cables in Jamaica having installed a new system in 2006.

2.3.1 The Cable

With over 20 submarine communication cables Caribbean waters, there has been no reported negative impact on the environment. The routing of each of the new cables has been based on avoiding any sensitive area such as coral reef and fish nurseries and proven techniques used during the recent construction of the original segments between the Jamaica and the United States of America and the Bahamas will be used for the installation.

The small size of the cable (Figure 2-2), the narrow path of the cable and the shortness of the construction phase are the major factors limiting the potential for impacts.

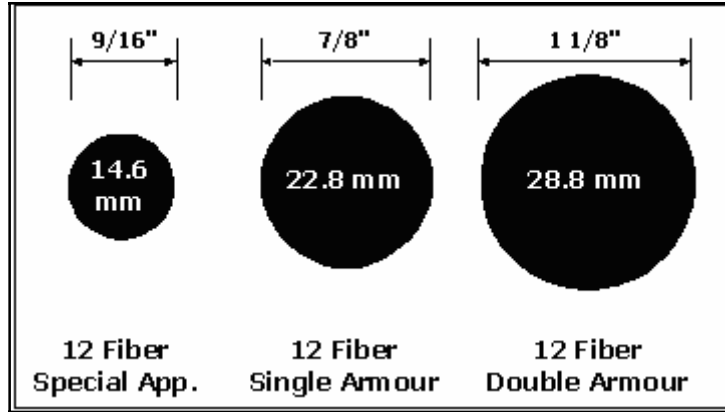
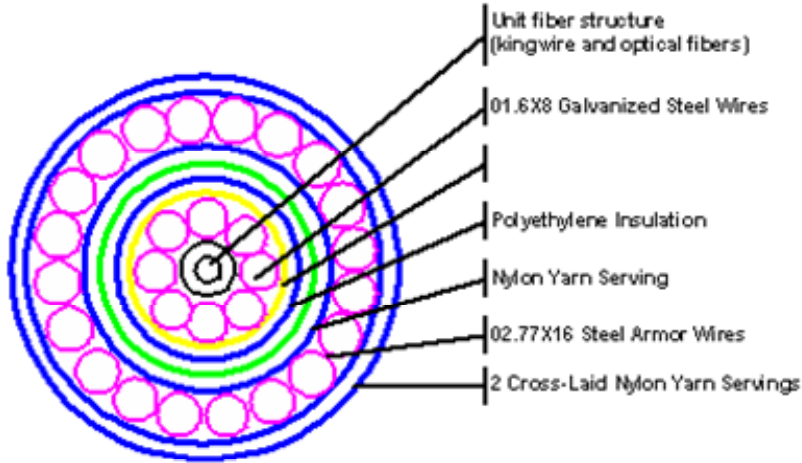

Figure 2-2: Fibre-Optic Cable Cross-Section

All non-repeated armoured fibre-optic submarine cables are basically constructed in a similar manner. Figure 2-3 below shows the typical components of such cables.



SL101 Single-Armored (SA) Cable Cross Section

OD = 22.8 mm (0.90")

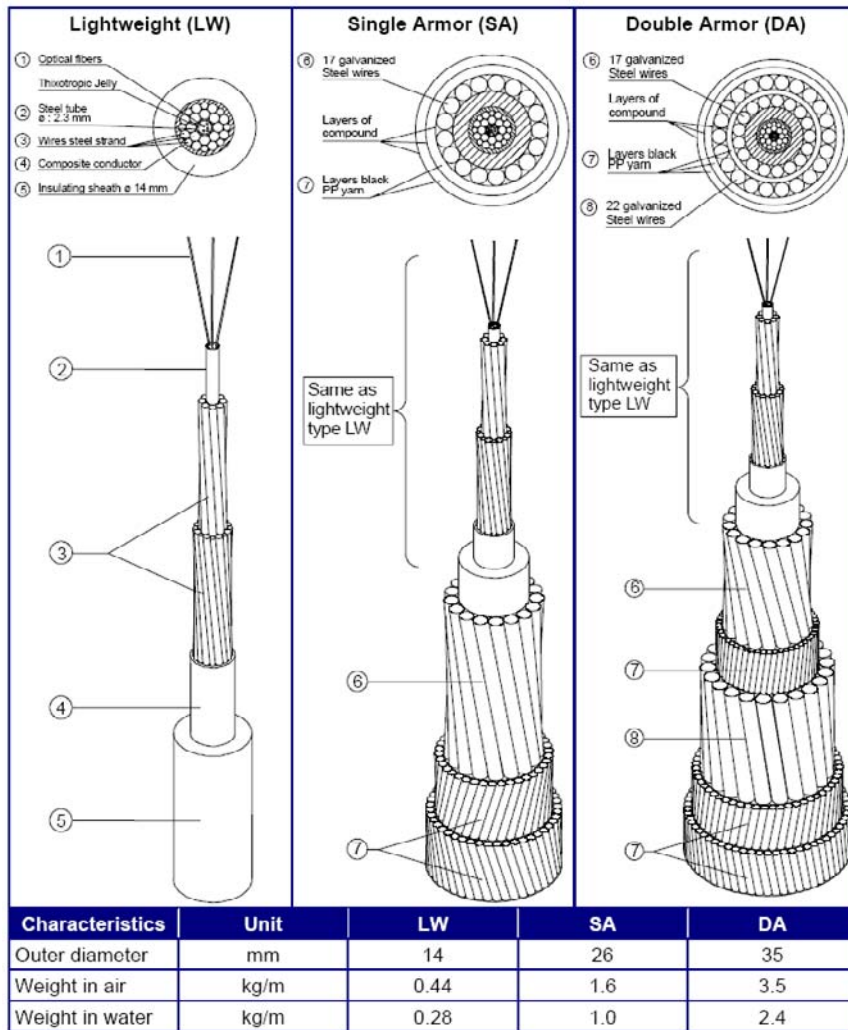

Figure 2-3: Typical Cross-section of a single armoured sub-marine fibre optic cable (Not to Scale)

To ensure longevity of the cable and to minimize the potential for breaks, it is important that the cable is laid in areas of soft sand bottom, away from coral and other hard marine structures and anchorages. Where necessary, the cable will be protected through the use of a boltless articulated pipe. The incorporation of the articulated pipe will also provide a self burial method, thus avoiding excessive disruption to the ocean floor (Figure 2-4).

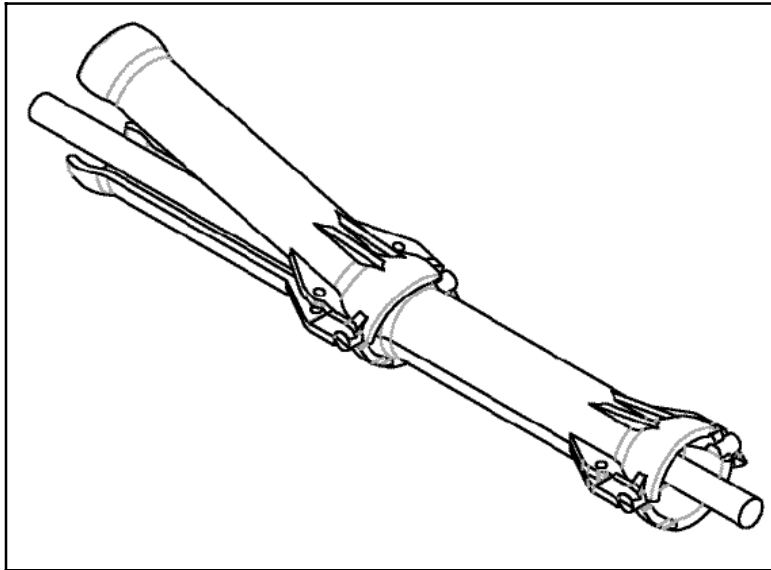

Figure 2-4: Articulated Piping to Protect the Submarine Cable

2.3.2 Proposed Implementation

The proposed development will factor in the various phases of a development such the pre-construction, construction and operational phases. This development similar to the previous cable lay by Fibralink will require approvals and be subjected to the requirements as laid out by law of the National Environment and Planning Agency (NEPA) and the respective Parish Council as well as any other relevant authorities.

Site preparation and construction schedules will take into account the traditional rainy season between May and October, including the hurricane season from June to November, during which tropical storm systems may bring tropical storm/hurricane winds with the potential to a bring a halt to all marine related works for a considerable period, and as such this project will be factored this eventuality.

The project is proposed to be implemented during the first week of December 2007.

During the pre-construction, construction, and operational phases employment will be for various types of workers including; engineers, labourers (skilled and unskilled), suppliers of goods and services, among others. The bulk of workers will be employed during the laying of the cables within the near-shore environment, to include boat handlers, divers etc.

The proposed phases of the project are as follows:

Phase	Description	Proposed Time Period
1 – Pre-Construction	Siting and development of nearshore infrastructure including manholes and ducts	1 week, December 2008
2 – Construction [Cable Lay]	Construction of nearshore manhole and ducts using horizontal directional drilling, laying and verification of cables using route markers, pulling of cable through ducts in nearshore waters, laying of cable in offshore waters	4-6 weeks, December 2008
3 - Operation	Commissioning of fibre-optic cable	Earliest 2 nd Quarter 2008

Activities to be undertaken in the various phases are outlined in the following sections.

Phase 1: Pre-Construction

Pre-construction activities include all site preparation activities such as

- identifying nearshore manhole location at the respective landing sites, and recorded their GPS coordinates
- Verification with pre-survey coordinate locations, and positioning of horizontal directional drill and associated equipment
- Re-verification of cable lay route through dive survey to ensure no new obstacles are present

Pre-construction waste that cannot be re-used, such as packing material and drill dredge will be disposed of at an approved facility such as the Riverton City Landfill which serves the South-

East region, and is managed by the MPM Waste Management Limited a regional division of the National Solid Waste Management Authority (NSWMA).

Phase 2: Construction [Cable Lay]

Construction activities include all activities geared towards the laying of the fibre-optic cable through ducts and on the seabed in the nearshore and offshore regions. All site works will be executed in accordance with international accepted standards similar to previous cable lay in Jamaica and elsewhere in the Caribbean as outlined in this report.

Fibralink and/or its Contractors will enter into discussion with the relevant authorities such as NEPA and the Marine Police among others, where necessary, to ensure the public is protected during the cable lay. Though the area is not an active marine traffic site, all precautions will be taken to protect life and property during the laying of the fibre-optic cable.

Cleared material from the installation of the marine duct to receive the cable and material removed in the construction of the nearshore manhole that will not be re-used will be disposed of at an approved facility such as the Riverton City Landfill which serves the South-East region, and is managed by the MPM Waste Management Limited a regional division of the National Solid Waste Management Authority (NSWMA).

Cables will be laid from a ship holding position offshore. Cable will be brought towards the landward duct location via small boat with cable attached to buoys prior to positioning on the seafloor. Protection of any marine resources such as coral will be done by divers wherever sensitive life-forms or marine interests are found in conjunction with inspectors from the relevant authorities.

No cables will be laid on or across and coral formation to protect both the cable and the life-forms.

Phase 3: Operation

Operation activities include the commissioning of the cables into power, the completion of station house, and connection to the existing Fibralink network. These activities represent the end product of the development to be kept in-situ into perpetuity.

The proposed mitigation measures incorporated in the engineering design will prevent problems of cable damage, damage to sensitive marine areas, most significantly loss of contact with the rest of the world during severe storms as happened most recently in 2004 with hurricane Ivan.

Mitigation measures proposed for all phases of the project are outlined in the Impact Identification and Mitigation section of this report (Section 7). Scheduled inspections and maintenance of the cable is critical and will be address by the monitoring plan to be put in plan as outlined later in this report (Section 8).

2.3.3 Landing Sites

FibraLink proposes two (2) landings to support the location of separate cables on the south coast of the island. The proposed landing sites are:

- Bull Bay, St. Andrew
- Prospect, St. Thomas

Landing site refers to the location that the cable comes ashore and may not be the location of the equipment building. In all cases, the equipment building will be located in a secured location close to the distribution network. Equipment buildings are ideally located in proximity to the landing site, with easy access to electricity and at an elevation in excess of 3 meters above sea level. Buildings are of the standard concrete and steel and will meet building codes as stipulated by the relevant authorities such as the St. Thomas Parish Council. The typical equipment building layouts and structural designs are detailed in Figure 2-5 - Figure 2-8 below.

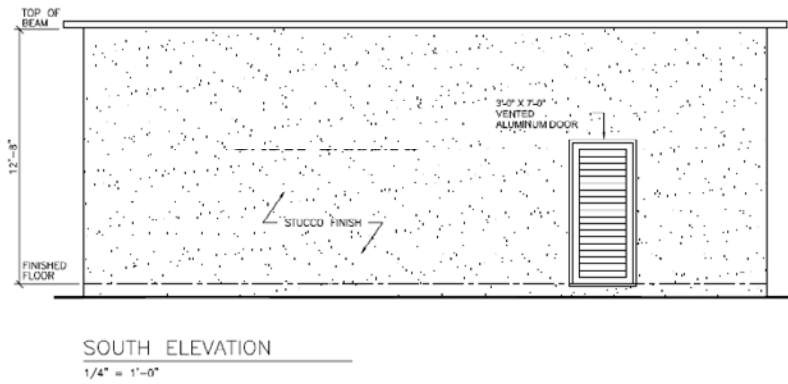
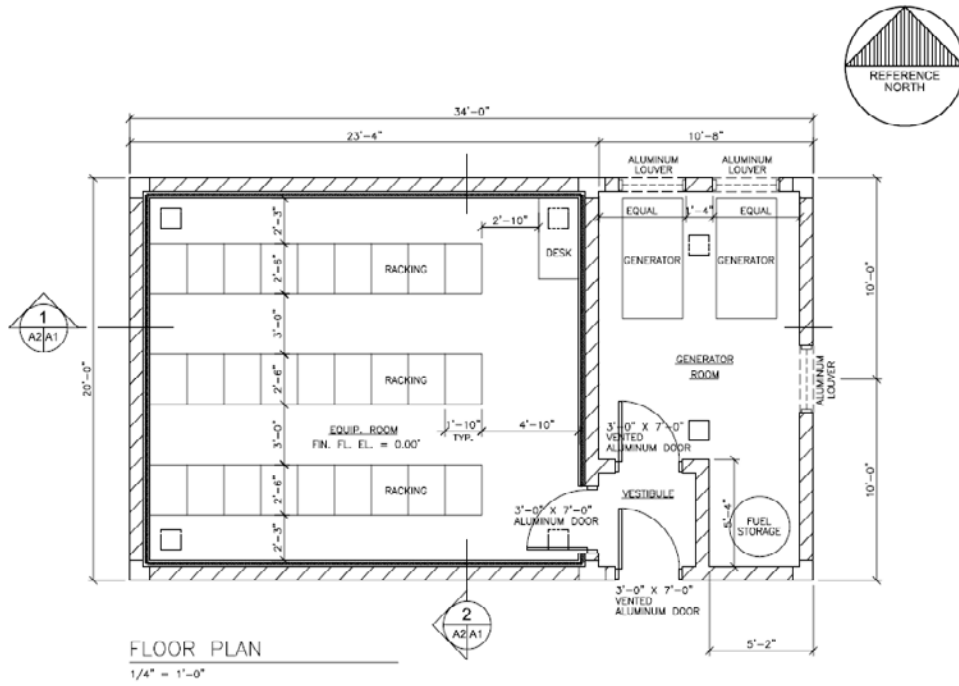
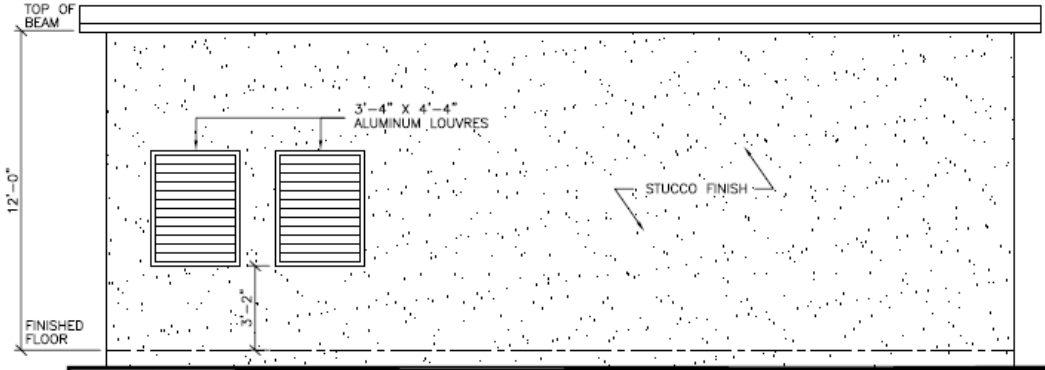
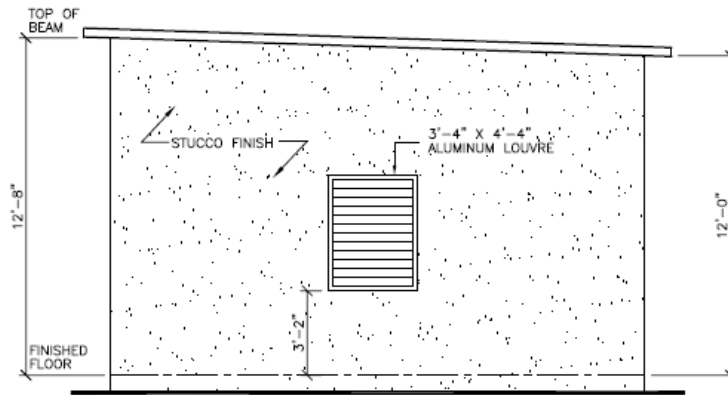

Figure 2-5: Typical Equipment Building Layout – Plan and Front End Elevations



NORTH ELEVATION

1/4" = 1'-0"



EAST ELEVATION

1/4" = 1'-0"

Figure 2-6: Typical Equipment Building Layout – Side End Elevations

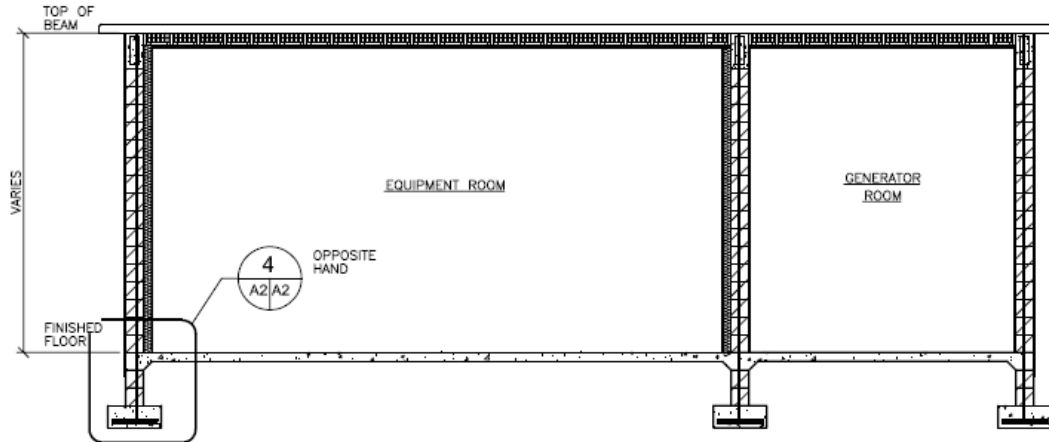

BUILDING SECTION

1/4" = 1'-0"

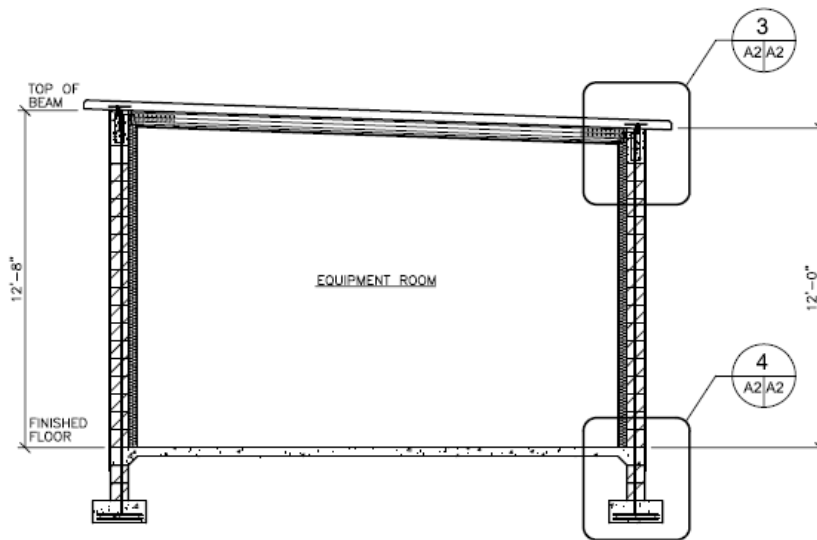

BUILDING SECTION

1/4" = 1'-0"



Figure 2-7: Typical Equipment Building Structural Design – Key Structural Design Areas Highlighted

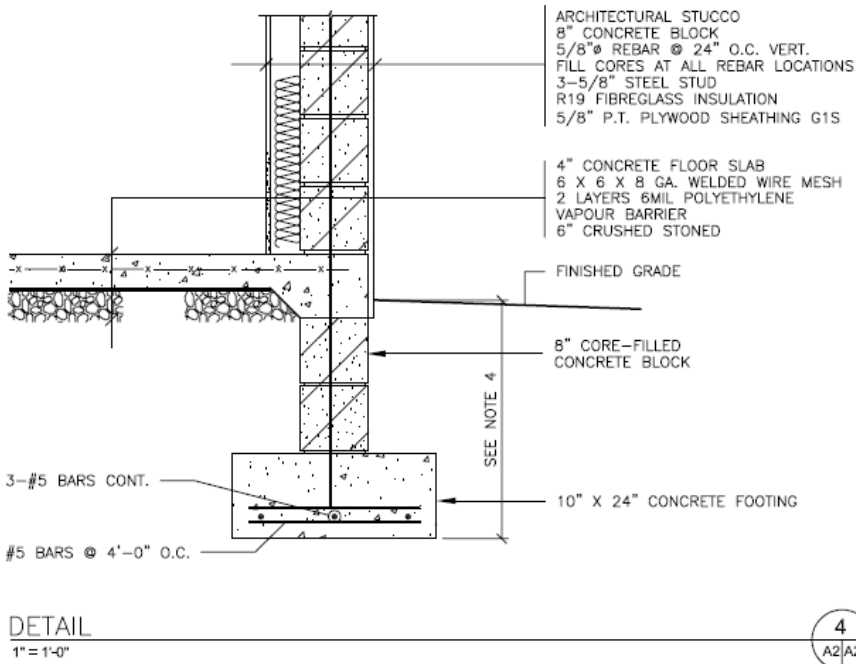
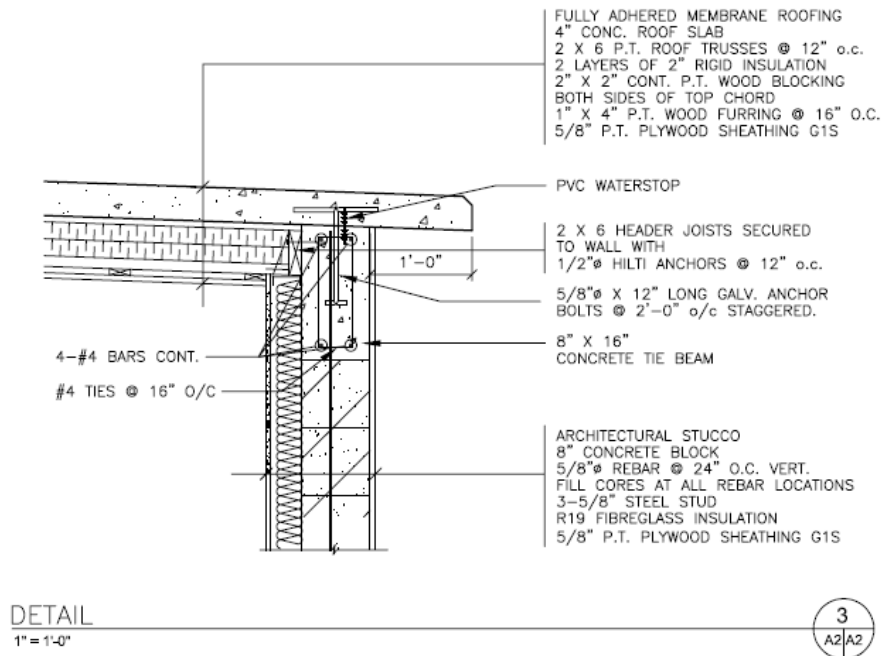

Figure 2-8; Typical Equipment Building Structural Design – Detailed overview of Key Structural Design Areas

2.3.3.1 Bull Bay Landing Site

The coastline within 1 - 4 km east of the Bull Bay landing is primarily an informal settlement area. Fishing activity is limited to small boat (canoe type) boats with nets, trawl and spear fishing. Vessel anchoring in the area is limited or none.

The coordinates for the Bull Bay Landing site are:

- North: 17° 56.553'
- South: 076° 41.379'

The beach and nearshore is primarily coarse black sand which appears to deepen slowly without any reefs present. It is similar to the existing Fibralink (AT&T) Bull Bay approach which is mainly coarse sand and small boulders without any coral present. This landing site provides excellent access for shore end activities (Figure 2-9).



Shoreline looking east



Shoreline looking west



BMH looking towards sea



BMH looking towards roadway

Figure 2-9: Shoreline Baseline

2.3.3.1.1 Physical Description

The location of the cable station is on Highway A4 in Bull Bay, which is approximately 7 kilometres east of the Harbour View round about, and ~1.7 km east of the existing Fibralink cable station.

The cable route then goes under the coastal road west towards the cable station that is approximately 35 m above sea level. All underground cable routes will utilize new and/or existing ducts, minimising disruption to the environment.

The building is a typical cable station; no windows, flat roof, with parking and loading dock access. This building is operational, no external modifications are necessary. The map and pictures below show the proposed route into Bull Bay, landing site and environs at Bull Bay (Figure 2-10 and Figure 2-1).

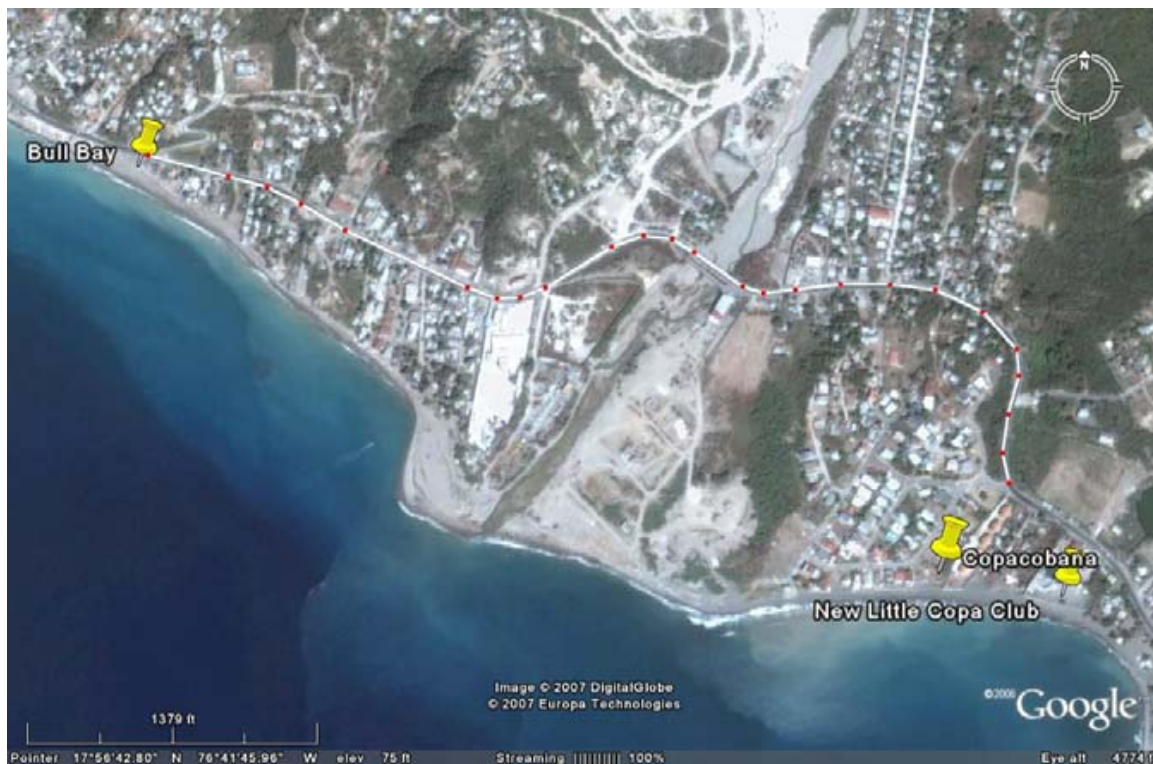

Figure 2-10: New Bull Bay Landing Site [Google Aerial Imagery]

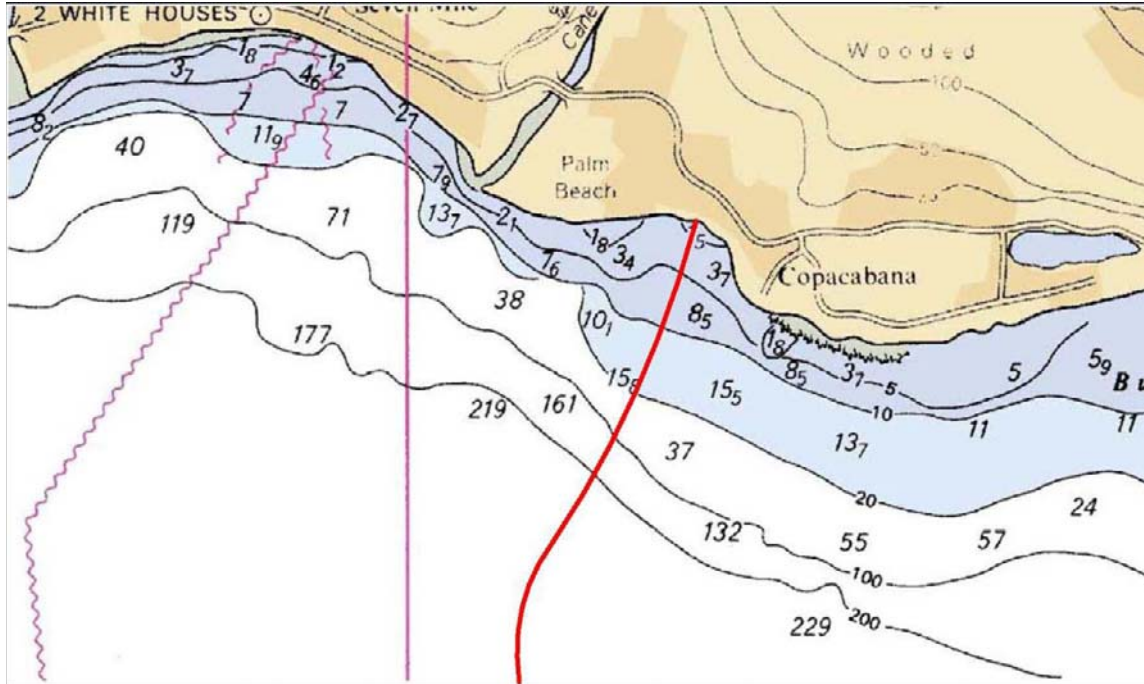

Figure 2-11: New Bull Bay Landing Approach

2.3.3.2 Prospect Landing Site

The coastline along this area has primarily shallow water less than 6 m water depth to a distance from the shoreline varying from approximately 50 m – 300 m with breaking waves on the seaward side where the depth appears to increase dramatically. Marine navigational charts indicate a deep water channel between the reefs in the area. The bottom in this channel consists mainly of sand. This channel may pose an increased difficulty during the landing of the cable due to its orientation but does provide some protection against heavy seas from the south.

Fishing activity is limited to small boat (canoe type) boats with nets, trawl and spear fishing. Limited or no vessel anchoring occurs in the area.

This entire area is within a developing community that can be described as organized middle/low income. The shoreline is a fine sand beach and slopes gently towards the channel. The beach manhole (BMH) location will be approximately 1.5 m above sea level and 10 m from the shoreline (Figure 2-12). The distance to the proposed cable station site is 600 m.

The coordinates for the Prospect Landing site is:

- North: 17° 51.865'
- South: 076° 20.450'

The site provides excellent access for shore end activities.



BMH looking towards beach



Beach looking towards sea

Figure 2-12: Shoreline at Prospect

2.3.3.2.1 Physical Description

The shoreline at Ocean View Close is primarily white sand and seagrass beds. The location of the cable manhole will be within the community of Prospect, specifically Ocean View Close, which is approximately 3 kilometres south-west of Port Morant or about 1 km east of Lyssons.

All underground cable routes will utilize new ducts and proven technology to minimise disruption to the environment.

The cable station will serve as both a good sub sea cable station and a distribution point for Flow's HFC network. The proposed site has coordinates 17° 52.088'N, 076° 20.652'W at an elevation of approximately 16m above sea level. The area is can best be described as a middle to low income community. Cable & Wireless underground passes within 30 m of the site, and a new Digicel tower site is within 60 m.

The map and pictures below show the proposed route into Bull Bay, landing site and environs at Bull Bay (Figure 2-13 to Figure 2-15)



Figure 2-13: Prospect Landing Site [Google Aerial Imagery]

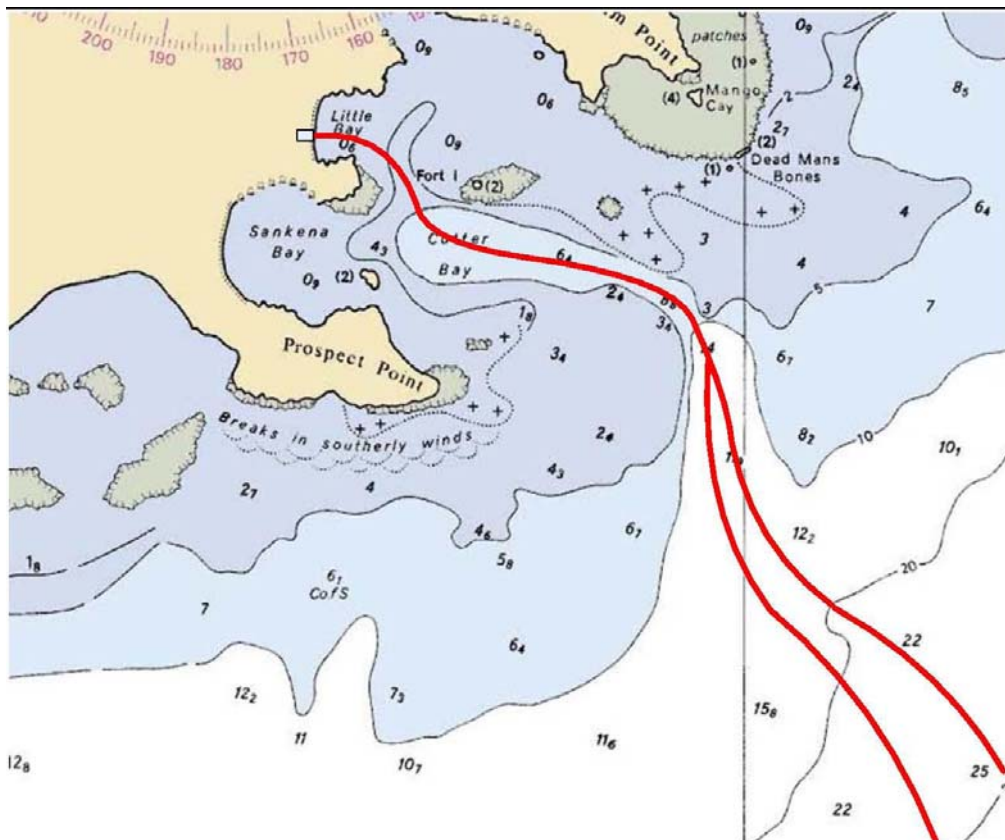

Figure 2-14: Prospect Landing Approach



Figure 2-15: Proposed Cable Station Sites

2.3.4 Marine Ducts and Near-Shore Manhole (NSM) Design and Construction Methodology

2.3.4.1 Marine Ducts Design

To minimize the impact near the beach and address the issues related to possible use of the area by fishermen and the public, the construction method most suitable was determined to be Horizontal Directional Drilling (“HDD”). HDD is done from an approximate distance of 15 m from the shoreline, thereby avoiding construction at the beach area.

This is an improved method of dealing with the nearshore compared with the trenching method used in previous installations. It allows users of the beach to continue use and avoids the negative aesthetic of trenching activities. The impact to the nearshore is also minimal.

The NSM will be constructed in the parking lot adjacent to the beach at the Bull Bay site, and within the right-of-way at Ocean View Close (Dead-end), Prospect, and drill four (4) 95 mm marine ducts that would extend beyond the lower water mark to a minimum distance of approximately 150 m. The nominal depth of drilling will be approximately 3.6 m – 6.0 m.

The HDD approach addresses concerns in relation to the following:

1. Environment;
2. Use of the public beach front and surrounding area;
3. Congestion that would result if the NSM were constructed at the shoreline; and
4. Avoids the disruptions that would result from shoreline excavations.

2.3.4.1.1 Construction Methodology

FibraLink will utilize a 2005 Ditch Witch JT2720 All Terrain HDD that it owns and operates in Jamaica (Plate 2-1). This specific HDD is intended for use in varying ground conditions such as solid rock, broken rock, cobble, and gravel. It can effectively make installations up to 200 m.



Plate 2-1: Horizontal Direction Drill - Ditch Witch JT2720

The trencher has numerous advantages over conventional trenching methods:

1. It reduces the installation time of the duct.
2. It minimizes the disturbance to the roadway by making the smallest possible trench. The use of cutters and back hoes causes 3 to 4 times the damage to the roadway;
3. The trench is closed everyday thereby minimizing potential washouts and disruption of traffic; and

4. Due to reduced labour cost, it reduces the per metre construction cost of the trench. Containing and minimizing costs helps ensure Jamaica can enjoy more competitively priced products and services.

Figure 2-16 above shows the trencher in operation. In the back of the photo, the trencher is cutting the trench. The work crew is cleaning the trench of excess material. Note that the cut is placed as far from the roadway as possible and the road remains open to traffic. Below is an example of a reinstated trench that was completed in a paved shoulder.



Figure 2-16: Trencher in Operation

Listed below is the equipment tool set

Item	Qty	Description
1	1	Ditch Witch HDD, Model JT2720 c/w transport trailer
2	1	Ford F650 Truck c/w mud mixer & 5000 litre water tank
3	1	FX30 Vac System c/w trailer
4		Ford F650 Truck c/w tools and drill rod inventory
5	1	Generators
6	2	50mm Electric Water Pumps
7	2	Jack Hammers
8	2	Compaction Rammers
9	1	Mobile trailer (for secure storage)

Item	Qty	Description
10	1	Compressor
11	2	Wheel barrows
12	Lot	Miscellaneous hand tools
13	30	Traffic cones

2.3.4.2 Near Shore Manhole & Back Haul Design

The marine ducts outlined above will terminate in a newly constructed Near Shore Manhole (“NSM”). The NSM is constructed underground of reinforced concrete. To limit the disturbance of the existing asphalt and to minimize the size of the excavation, a rubber tire backhoe will be used. After the casting of the NSM, the excavation will be backfilled and compacted in lifts not exceeding 300 mm, the excess material will be removed from site and disposed at an approved location. The backfilling will terminate a minimum of 50 mm below the existing asphalt; the edges of the existing asphalt will be cut with a rotary saw and will receive a coating of liquid asphalt before the asphalt pavement is reinstated. The NSM construction drawings are outlined below (Figure 2-17 and Figure 2-18). Figure 2-19 and Figure 2-20 show the proposed location for NSM at the selected sites.

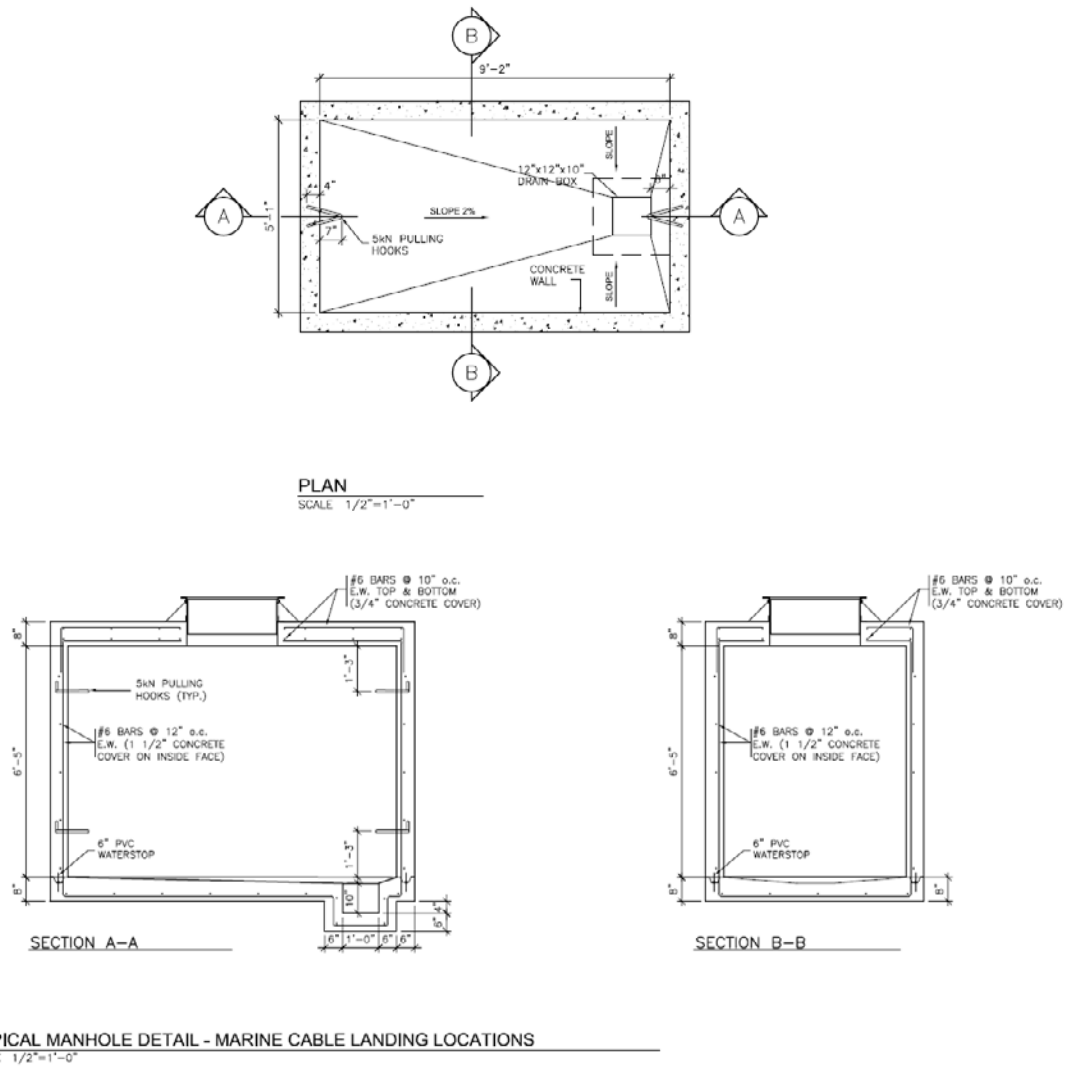
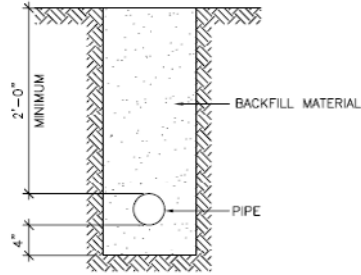
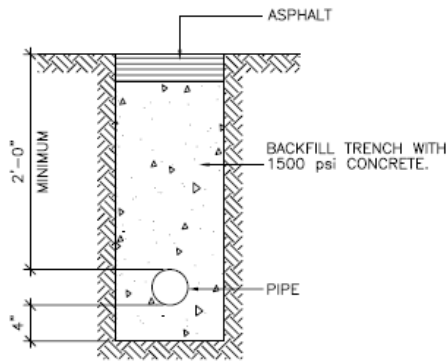

Figure 2-17: Typical Manhole Detail



TYP. TRENCH DETAIL IN ROAD SHOULDER
SCALE 1"=1'-0"



TYP. TRENCH DETAIL IN ASPHALT AREA
SCALE 1"=1'-0"

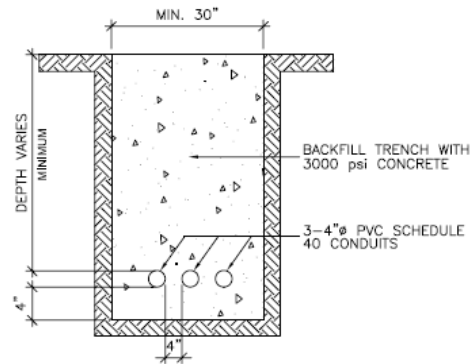

TYP. TRENCH DETAIL AT SHORELINE
SCALE 1"=1'-0"

Figure 2-18: Trenching Details



Figure 2-19: Bull Bay - Location of Manhole in Proximity to roads and buildings



Figure 2-20: Prospect - Proposed Manhole Location at Ocean View Close

The back haul of the land cable will be from the NSM to the cable stations. In St. Thomas it will be via newly constructed underground fibre cable ducts along the roadway to a newly constructed cable station proposed to be in the Morant Point area. This route is approximately 1.0 km long. There is existing water and sewer services along the route and will be coordinated with the appropriate utilities authority. The installation will utilize purpose built trenching machinery as described in Section 2.3.4.1.1 below.

There will be four 75 mm schedule 40 HDPE smooth PVC ducts. The ducts will be placed, where possible, along the shoulder of the roadway to avoid disruption of the asphalted driving surface. The excavation will be a maximum of 300 mm wide x 900 mm deep. Existing grades will be maintained. To mitigate against potential washouts trenches will be closed daily.

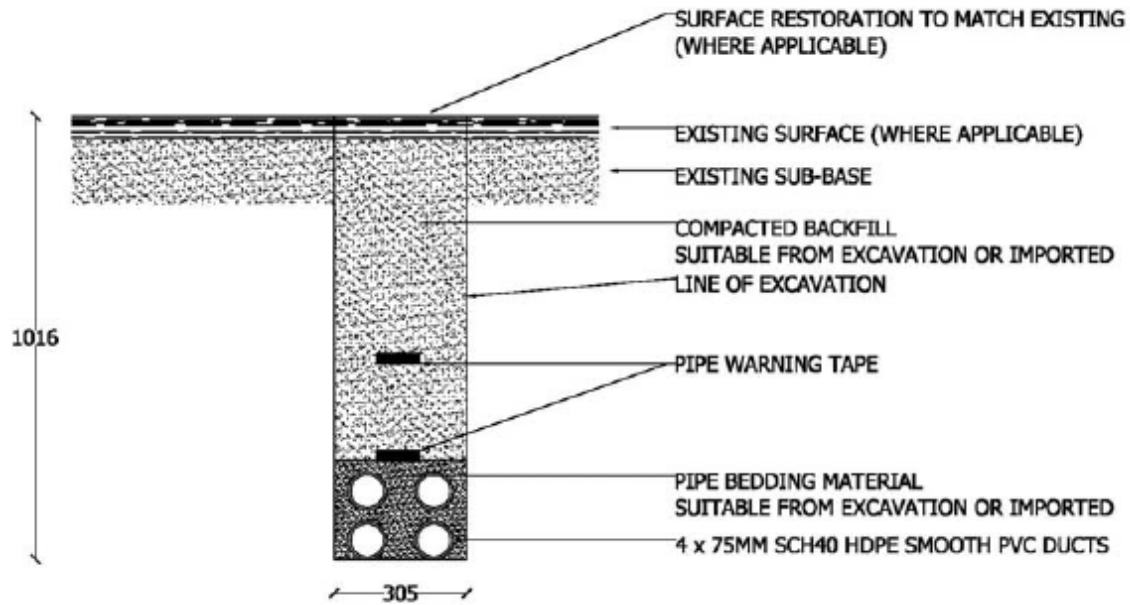

Figure 2-21: Back Haul - Trench Cross-Section

Hand holes for pulling the cable are placed at a minimum distance of 150 m apart and a maximum of 300 m. The hand holes will be underground and will have inside dimensions of 1.05 m x 1.05 m x 0.85 m high. There will be 900 mm diameter lockable cast iron covers at each hand hole. The hand holes are placed along the entire route for the primary purpose of pulling cables into the ducts.

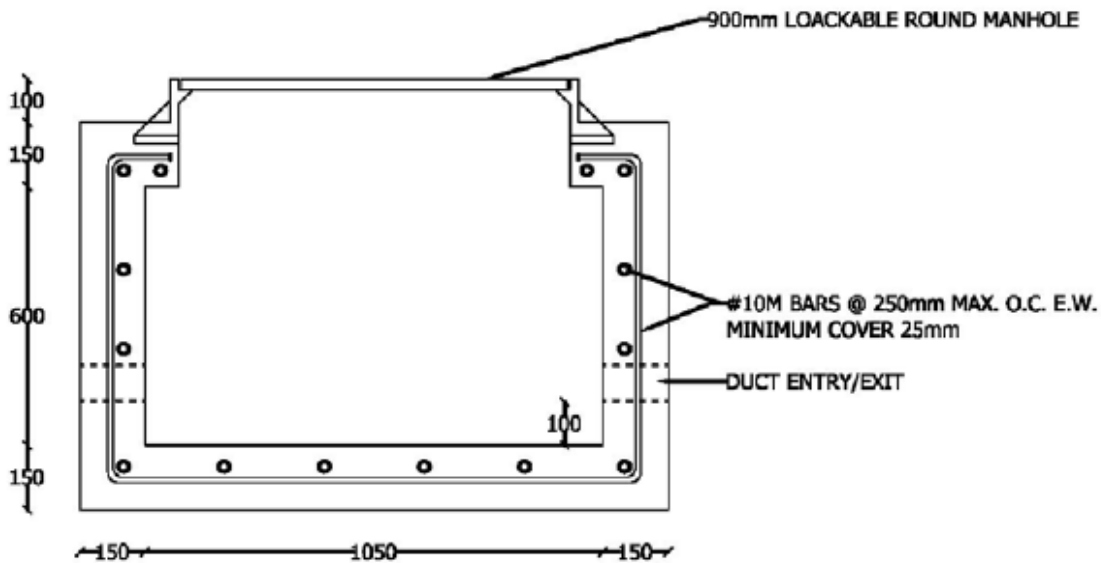

Figure 2-22: Back Haul - Hand Hole Section

During the construction process all disruption will be reinstated to at least the standard of the prior existing conditions. This includes backfill compaction and surface reinstatement (Figure 2-23).

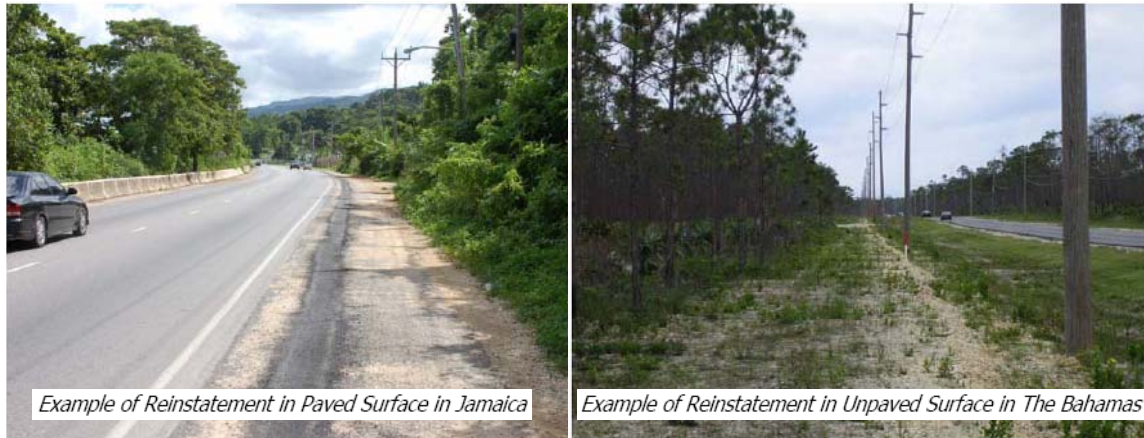

Figure 2-23: Reinstated Roadways

2.3.4.2.1 Construction Methodology

The construction of the NSM will utilise a qualified local contractor experienced in such activities. FibraLink’s affiliate, Flow Jamaica has an extensive list of qualified civil engineers and contractors in Jamaica given its various expansion activities and ongoing cable TV operations. FibraLink’s underground construction supervisor will oversee the entire process.

2.3.5 Recommended Fibre-Optic Cable Installation Techniques

This section details preliminary installation operations based on available information, experience and standard technology

2.3.5.1 Route Surveys

A marine route survey has been conducted. The main objective of the marine route survey along the projected cable routes was to develop sufficient bathymetric data to engineer and install the fibre optic cable.

Diver swim surveys have also been conducted in the shallow water sections. This was done in order to find an appropriate route; thereby avoiding any kind of obstacles and sensitive features such as coral reefs and sea grass areas.

Based on the information obtained from the Route Surveys, a suitable cable route was selected. Illustrations of the inshore topography for the various selected route segments of the installation are illustrated in Section 2.3 above.

2.3.5.2 Cable Installation

There are two separate operations required for cable installation, which are:

- Shore end operations
- Deep-water operations

The shore end activities are more site specific and are detailed based on the landing site. The redundancy of the system allows for two-switch-traffic, where the two separate cables coming into Jamaica are independent of each other so that the end user will not experience a disruption in their service should any one cable becomes damaged and taken out of service for repairs.

2.3.5.2.1 Laying Vessel

A cable ship or converted flatback vessel (offshore supply) will be used to install the cable. If using a flatback vessel, all the necessary equipment to manipulate the cable will be installed and tested prior to the start of the operations. The typical vessel deck layout is represented below (Figure 2-24). The main necessary equipment are as follows:

- Cable tank with an internal cone respecting the minimum radii of curvature of the cable.
- Caterpillar or linear cable engine (5 tons capacity).
- 20 feet container for splicing operations
- Small crane (3 tons capacity)

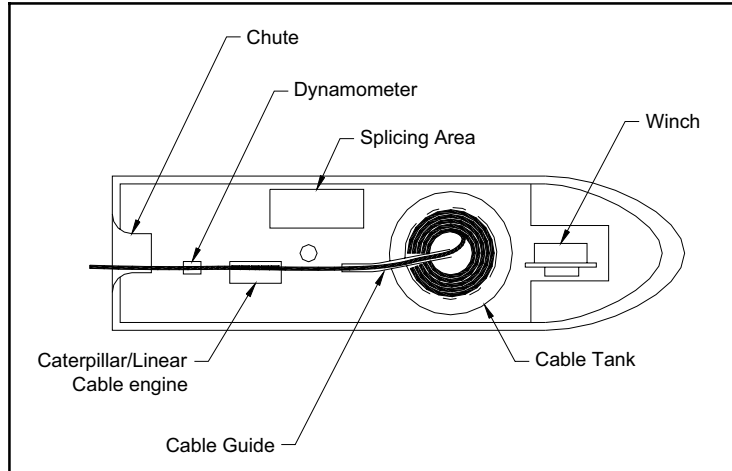

Figure 2-24: Typical Deck Layout

2.3.5.2.2 Shore End Operations

The shore end superintendent will conduct a radio check prior to the start of cable pulling operations. The key personnel will be called and asked to respond individually: vessel aft deck, vessel bridge, winch operator, and dive boat. The shore superintendent will then commence the shore end pulling operations (Plate 2-2).



Plate 2-2: Illustration of Installation from Ship with a Sheave

The main lay vessel will be positioned near the seaward end of the directionally drilled pipe, in approximately 11 m of water. The pull wire in the pipe will be retrieved by the diver and handed off to the dive boat operator who in-turn will pass the line to the ship. A 28.575 mm (1 1/8") uniline will be attached to the pull wire and pulled ashore using the winch stationed near the manhole (Plate 2-3).

When the uniline is secured on shore, the ship will be advised. The deck crew will attach the cable to the uniline using a 6000 lb Miller or similar swivel and a Yale cable grip. The deck crew will then advise the shore-end superintendent that pulling can proceed. The divers will follow the cable end to the pipe and ensure that the cable enters the pipe smoothly. The deck crew aboard ship will closely monitor payout tensions and draw speed as the cable is pulled into the manhole.



Shore-end Manhole Winch



Cable Lay Route

Plate 2-3: Illustration of Installation with a Winch on the Shore; Buoyed Cable on the Right

When the cable reaches the shore and sufficient cable slack has been brought ashore the cable will be stoppered off to the line vehicle. The ship will make ready to start laying cable and move off at a speed of approximately 0.5 m/s (1.0 knots). Cable will be surface laid throughout the route (Figure 2-4).



Plate 2-4: Illustration of Installation Using a Landing Craft

In order to reduce the potential impact to hard-bottom substrate, the route has been designed to avoid crossing high-relief outcrops.

After the ship has laid the cable, the divers will swim the length of the cable from the end of the duct to a water depth of 85 ft to ensure that the cable is lying on the bottom and no suspensions exist. Any minor suspensions will be removed by hand. If the divers discover more severe suspensions the cable ship will evaluate recovering the cable, clear the suspension and re-lay the cable. Once divers have confirmed that the cable is satisfactorily positioned, the ship will resume laying. When approximately 2.5 km of cable have been laid, the stopper will be released on shore. The manhole clamp will be installed on the cable.

The following table outlines the typical shore-end equipment (Table 2-2).

Table 2-2: Typical Shore End Equipment List

Equipment		Details
Support Vessel	Small Vessel such as a 16' Zodiac equipped with an outboard motor for the shore crew and divers	
Shore vehicles	Line truck Winch or winch vehicle Shore transportation (Car or Van) Splicing van	Stand by vehicle to act as emergency backup or stopper Min Capacity of 6 tons line pull
Special Equipment	2 x 18" diameter sheaves Cable slider 5" snatch blocks (2) 2000' of 1 1/8" diameter Uniline. Cable guides Shore power 5000 watt generator Lights Rotary impact drill or air tool with air supply Hand tools (full set) Barricades and safety tape Traffic control and work area protection	To be set up in the manhole to guide and redirect the cable and maintain minimum bending radiuses

2.3.5.2.2.1 Splicing Operations

Splicing operations will start as soon as the clamp has been installed on the cable. The splicing will take place in a climate controlled environment vehicle. Upon completion of the manhole splice the cable will be tested bi-directionally using set-ups at the cable station and aboard ship. Satisfactory results will allow the splicers to permanently close the manhole joint.

2.3.5.2.3 Deep Water Operations**2.3.5.2.3.1 Laying Specifications**

After receiving confirmation that cable is securely anchored, the vessel starts to move seaward.

Care will be exercised over the slack control as the vessel moves away from the shore end landing position to avoid pulling the cable and inducing suspensions.

The cable is surface laid throughout the whole lay. Cable is paid out from the linear cable engine as the vessel advances along the planned cable route.

Throughout lay operations, the cable tension will be monitored and adjusted as necessary to maintain the design level installation slack in the cable. The vessel shall move in a straight path from its position during landing operations to the first alter course. Movement between this alter course position and subsequent alter courses must also be a straight path.

The ship stops at the next site shore end position and starts shore end landing operations as described in corresponding shore end section.

2.3.5.2.4 Final Splice Optional Laying Scenario

In case of bad weather or unforeseen events, a direct lay as described in the previous section might not be possible. A 2-segment lay with a final splice would then be necessary.

2.3.5.2.4.1 First lay

After receiving confirmation that cable is securely anchored, the Master of the laying vessel instructs the tug (if used) to release the mooring lines. The vessel then starts to move seaward. Care must be exercised over the slack control as the vessel moves away from the shore end landing position to avoid pulling the cable and inducing suspensions.

The cable is surface laid throughout the whole lay.

Cable is paid out from the linear cable engine as the vessel advances along the planned cable route. Throughout lay operations, cable tension measured at the stern dynamometer is maintained in strict accordance with the provided tension tables. The vessel shall move in a straight path from its position during landing operations to the first alter course. Movement between this alter course position and subsequent alter courses must also be a straight path.

Lay operations then continue on the planned route. At the end of the lay i.e. at the final splice location, 50 m of line are streamed along the cable route and a temporary anchor 113 kg (250 lbs.) concrete clump placed. The end of the Uniline is then buoyed off.

2.3.5.2.4.2 Cable Recovery

While proceeding to the buoy position, all required deck equipment, (i.e., hack lines, recovery line, lashing & stoppers) is staged as required.

Cable splicing equipment are broken out and tested prior to recovery of the cable.

Cable end buoy is recovered.

When the Uniline begins to take a lead to the cable end, the vessel begins moving to the cable end as the rope is recovered.

The vessel proceeds in this manner until a sufficient amount of the laid cable is onboard to perform the splice.

2.3.5.2.4.3 Final Splice

End of both cables is fed into the splicing area.

Splicing personnel proceed with the final splice.

The fibres are terminated and tested.

When the final splice is completed and the tests show no fault, the cable is out board. The system should be tested when touching the seabed, before cutting the lowering line.

2.3.6 Cable Repair Techniques

The following section briefly touches on cable maintenance and repair. All submarine cables are susceptible to failure from external sources, such as fishing activity and anchor mauls. The following table gives the percentage of failure causes for 380 reported cable faults. Careful planning and implementation can greatly reduce the risk of such failures. Initial prevention will result in a highly reliable telecommunications facility.

Table 2-3: Percentage of Failure Causes for 380 Reported Cable Faults

Cause	Count	%
Abrasion	18	4.7%
Anchor	49	12.9%
Branching Unit	2	0.5%

Cause	Count	%
Cable or Survey Ship Activity	5	1.3%
Dredging/Drilling and Pipe Installation	12	3.2%
Earthquake or Seabed Movement	10	2.6%
Equaliser	1	0.3%
Fatigue	1	0.3%
Fishing Activity	184	48.4%
Impact by Hard Object	5	1.3%
Insulation Failure	3	0.8%
Jointing Box	5	1.3%
Manufacturing Defect - Cable	4	1.1%
Repeater	17	4.5%
Unknown - Cable Deliberately Cut	1	0.3%
Unknown - Cable Mauled	6	1.6%
Unknown - Cable not repaired	1	0.3%
Unknown - Fibre Attenuation	5	1.3%
Unknown - Kinks, Twists, Loops	9	2.4%
Unknown - Shunt Fault	31	8.2%
Unknown - Tension Break	11	2.9%
TOTAL	380	

2.3.6.1 Canvassing Offshore Industries

Fibralink will make strong representations to the governments to have the cable route declared a prohibited anchorage.

If bottom fishing abounds in the vicinity of the route, it will be appropriate to establish a program of liaison and dialogue with the industry. Hydrographic charts could be personalized to highlight the route and carry suitable warnings and be distributed free with other promotional items.

2.3.6.2 Repair Methodology

When a cable system is interrupted, tests are made from terminals or suitable access points ashore to localize the trouble to an accurate geographical position, as derived from laying records. This localization will dictate the repair method to be selected, as follows:

2.3.6.2.1 In Diver-Depths

When the interruption is close inshore (preferably less than 20 m), a barge can be mobilized and moored over the site. Diving inspection or an electronic probe will locate the damaged area.

In the case of an electronic probe, a low frequency tone (e.g. 25 Hz) is injected on the centre conductor from the terminal. The probe in its various forms is deployed close to the cable. This will detect either the electromagnetic or electrostatic field developed along the cable. The range of the signal decreases with the length from the terminal but should cause no problems in this case. Probes can be a diver hand held device or attached to a two conductor cable towed from a surface vessel (towed electroding).

This technique permits accurate location of the cable and further, will usually indicate the fault location by registering a significant change in signal field strength at that point.

The ends will be hauled (or floated) to the surface and secured at the barge. After suitable electrical/optical tests have confirmed no other interruptions are present, a new spare piece is jointed/spliced in and the bight lowered, under controlled conditions, to the seabed. If appropriate the exposed cable will be diver-jettied into the seabed.

2.3.6.2.2 Conventional Method in Deep Water

The assigned repair vessel travels to the location and, if appropriate, establishes the precise position of the interruption by means of electroding. The vessel then using a special de-trenching grapnel, grapples across the cable and raises it to the surface. The bight of cable is hauled inboard on the grapnel and secured. After cutting the bight, the ends are opened and tested. In the ideal case testing in one direction will establish its mechanical/transmission integrity while testing in the other direction will indicate the break to be close to the ship.

After sealing and buoying off the good end, the short stray end is recovered to a spare storage tank or coil space and the ship proceeds to grapple for the end on the far side of the break. She raises the bight of cable, boards it, cuts the bight and tests. If everything is satisfactory she then splices on replacement cable, from a storage tank or coil on board, to the good end and pays this down to the seabed while steaming towards the buoyed end.

When the cable buoy has been recovered and the first good end tested and confirmed to be still OK the payout is terminated and the replacement cable is cut on the foredeck. Its end is joined to the recovered end and a final splice is made, whereupon the bight of cable is lowered to the seabed. After appropriate transmission tests have been made, the system can be returned to traffic.

Mobilization would comprise loading the replacement cable, gathering such customer specialists and equipment as are required and proceeding to site. The first alternative to a dedicated cable ship as above would be to engage an offshore flatback on spot-charter, if available, and spend some days fitting out and mobilizing as above for the repair. Then proceed to site.

2.3.6.3 Spare Cable and Repair Facilities

Spare cable and repair plant will be located as close to the cable route as possible, or at the base of the dedicated cable ship or ship of opportunity. Spare cable will be stored in a sheltered, temperature-controlled environment and be readily available for loading to ship at a deep-water berth.

2.3.7 Waste Streams

This project has minimal waste being generated. The primary waste streams are:

1. Cable Station – construction waste
2. Nearshore manhole – minimal soil removal
3. Undersea Nearshore duct – Drill waste

All identified waste stream will contain non-toxic material that are currently being disposed of in landfills in Jamaica. Where practicable, Fibralink will employ recycling techniques to limit the nature of the waste such as the use of soil material in reinstatement of roadways.

POLICY, LEGISLATION AND REGULATORY FRAMEWORK

3 Legislative and Regulatory Framework

3.1 Introduction

The policies, legislation, regulations and environmental standards of the Government of Jamaica (GOJ), which pertains to this development have been researched and analysed, to ensure that the project complies with all policy, legal and regulatory requirements. The areas examined included environmental quality, health and safety, protection of sensitive areas, protection of endangered species, site selection and land-use control at the regional, national and local levels, which relate to or should be considered within the framework of the project (Table 3-1).

Table 3-1: Summary of the Applicable Legislation and the Responsible Agencies

LEGISLATION	INSTITUTION RESPONSIBLE
Natural Resources Conservation Authority Act, 1991	Natural Resources Conservation Authority/National Environment and Planning Agency
Wildlife Protection Act, 1945	Natural Resources Conservation Authority/National Environment and Planning Agency
Beach Control Act, 1956	Natural Resources Conservation Authority/National Environment and Planning Agency
Town & Country Planning Act, 1987	Town Planning Department
Jamaica National Heritage Trust Act, 1985	Jamaica National Heritage Trust
Public Health Act, 1985	Ministry of Health [Environmental Control Division]
National Solid Waste Management Authority Act, 2001	National Solid Waste Management Authority
St. Thomas Development Order	Town Planning Department

3.2 National Policies

3.3 Applicable Legislation

3.3.1 *The Natural Resources Conservation Authority Act, 1991*

The NRCA Act addresses the designation of National Parks and Protected areas, and their development. It is also concerned with

Designation of national park, protected area, etc

5.- (1) The Minister may, on the recommendation of the Authority after consultation with the Jamaica National Heritage Trust, by order published in the Gazette designate-

- a. any area of land as a national park to be maintained for the benefit of the public;
- b. any area of land or water as a protected area in which may be preserved any object (whether animate or inanimate) or unusual combination of elements of the natural environment that is of aesthetic, educational, historical or scientific interest; or
- c. any area of land lying under tidal water and adjacent to such land or any area of water as a marine park.

(2) The Authority shall cause any order made under subsection (1) to be published once in a daily newspaper circulating in Jamaica.

Permit required

Section 9.-

(1) The Minister may, on the recommendation of the Authority, by order published in the Gazette, prescribe the areas in Jamaica, and the description or category of enterprise, construction or development to which the provisions of this section shall apply; and the Authority shall cause any order so prescribed to be published once in a daily newspaper circulating in Jamaica.

- (2) Subject to the provisions of this section and section 31, no person shall undertake in a prescribed area any enterprise, construction or development of a prescribed description or category except under and in accordance with a permit issued by the Authority.
- (3) Any person who proposes to undertake in a prescribed area any enterprise, construction or development of a prescribed description or category shall, before commencing such enterprise, construction or development, apply in the prescribed form and manner to the Authority for a permit, and such application shall be accompanied by the prescribed fee and such information or documents as the Authority may require.
- (5) In considering an application made under subsection (3) the Authority-
 - a. shall consult with any agency or department of Government exercising functions in connection with the environment; and
 - b. shall have regard to all material considerations including the nature of the enterprise, construction or development and the effect which it will or is likely to have on the environment generally, and in particular on any natural resources in the area concerned and the Authority shall not grant a permit if it is satisfied that any activity connected with the enterprise, construction or development to which the application relates is or is likely to be injurious to public health or to any natural resources.
- (6) The Authority may-
 - a. grant a permit subject to such terms and conditions as it thinks fit; or
 - b. refuse to grant a permit, and where the Authority refuses to grant a licence it shall state in writing the reasons for its decision and inform the applicant of his right under section 35 to appeal against the decision.
- (7) Any person who contravenes any provisions of subsection (2) shall be guilty of an offence and shall be liable on summary conviction before a Resident Magistrate to a fine not exceeding fifty thousand dollars or to imprisonment for a term not exceeding two years or to both such fine and imprisonment, and-
 - a. where a person defaults in the payment of a fine imposed under this subsection, he shall be liable to imprisonment for a term not exceeding one year; and

- b. where the offence is a continuing offence, he shall be liable to a further fine not exceeding three thousand dollars for each day on which the offence continues after conviction.

Power of Authority to request Marine Assessment, etc

Section 10.-

- (1) Subject to the provisions of this section, the Authority may by notice in writing require an applicant for a permit or the person responsible for undertaking in a prescribed area, any enterprise, construction or development of a prescribed description or category-
 - a. to furnish to the Authority such documents or information as the Authority thinks fit, or
 - b. where it is of the opinion that the activities of such enterprise, construction or development are having or are likely to have an adverse effect on the environment, to submit to the Authority in respect of the enterprise, construction or development, an Marine Assessment containing such information as may be prescribed, and the applicant or, as the case may be, the person responsible shall comply with the requirement.
- (2) A notice issued pursuant to subsection (1) shall state the period within which the documents, information or assessment, as the case may be, shall be submitted to the Authority.
- (3) Where the Authority issues a notice under subsection (1), it shall inform any agency or department of Government having responsibility for the issue of any licence, permit, approval or consent in connection with any matter affecting the environment that a notice has been issued, and such agency or department shall not grant such licence, permit, approval or consent as aforesaid unless it has been notified by the Authority that the notice has been complied with and that the Authority has issued or intends to issue a permit.
- (4) Any person who, not being an applicant for a permit, refuses or fails to submit an Marine Assessment as required by the Authority shall be guilty of an offence and shall be liable

on summary conviction before a Resident Magistrate to a fine not exceeding thirty thousand dollars.

Revocation of permit

Section 11.-

- (1) Subject to subsection (2), the Authority may by notice addressed to the person to whom a permit was issued revoke or suspend the permit if it is satisfied that there has been a breach of any term or condition subject to which the permit was granted, or if such person fails or neglects to submit to the Authority, in accordance with section 10, any documents, information or assessment required thereunder.
- (2) Except as provided in subsection (3), the Authority shall, before revoking a permit, serve on the person to whom it was granted a notice in writing-
 - a. specifying the breach or default on which the Authority relies and requiring him to remedy it within such time as may be specified in the notice, and
 - b. informing him that he may apply to the Authority to be heard on the matter within such time as may be specified in the notice.
- (3) The Authority shall not be obliged to serve a notice pursuant to subsection (2) in relation to any breach if a cessation order pursuant to section 13 or an enforcement notice pursuant to section 18 is in effect in relation to that breach.

Cessation order

13.-

- (1) Without prejudice to the provisions of section 9 (7), 10 (4), 11 and 12 (3)-
 - a. where a person fails to comply with the provisions of section 9 (2); or
 - b. where the person responsible fails to submit an Marine Assessment within the time specified by the Authority; or
 - c. where a person fails to comply with the provisions of section 12 (1), the Authority may issue an order in writing to such person directing him to cease, by such date

as shall be specified in the order, the activity in respect of which the permit, licence or Marine Assessment, as the case may be, is required.

- (2) Where the person to whom an order is issued under subsection (1), fails to comply with the order, the Minister may take such steps as he considers appropriate to ensure the cessation of the activity to which the order relates.

Where authorized by the Minister acting pursuant to subsection (2), a member of the Jamaica Constabulary Force may use such force as may be necessary for the purpose of ensuring compliance with an order referred to in that subsection; and any person who hinders or obstructs any such member acting as aforesaid shall be guilty of an offence and shall be liable on summary conviction before a Resident Magistrate to a fine not exceeding ten thousand dollars or to imprisonment for a term not exceeding one year.

3.3.2 *The Wildlife Protection Act, 1945*

This act involves the declaration of game sanctuaries and reserves, game wardens, control of fishing in rivers, protection of specified rare or endemic species.

The Act also provides for the protection of animals and makes it an offence to harm or kill a species that is protected. It stipulates that, having in one's possession "whole or any part of a protected animal living or dead" is illegal.

This Act was consulted for the proposed project due to the possibility of such animals being found on the proposed site or in the adjacent waters. In addition, under this Act, provision has been made for the pollution of rivers, whereby it is an offence to discharge any substances into any river, which may be harmful to fish.

3.3.3 *The Beach Control Act, 1956*

This act was passed in an effort to properly manage the coastal and marine resources of Jamaica. This occurs through the necessary licensing of activities on the foreshore and the floor of the sea.

The Act also addresses access to the shoreline, fishing, public recreation, and the establishment of marine protected areas.

3.3.4 *The Town and Country Planning Act*

The Town and Country Planning Act covers the development and use of land. In accordance with this law, the Town Planning Department is the Agency that reviews any plans involving industrial development.

This law allows specific conditions to be stipulated and imposed on any approved plans. This planning decision is based upon several factors including;

- the location of the development
- the nature of the industrial process to be carried out
- the land use and zoning
- the effect of the proposal on amenities and traffic among other things.

Applications to local planning authority for permission

11.-

(1) Subject to the provisions of this section and section 12, where application is made to a local planning authority for permission to develop land, that authority may grant permission either unconditionally or subject to such conditions as they think fit, or may refuse permission; and in dealing with any such application the local planning authority shall have regard to the provisions of the development order so far as material thereto, and to any other material considerations.

(1) (A) where the provisions of section 9 of the Natural Resources Conservation Authority Act apply in respect of a development which is the subject of an application under subsection (1), planning permission shall not be granted unless-

- a. an application to the Natural Resources Conservation Authority has been made as required by such provisions as aforesaid; and
- b. that Authority has granted or has signified in writing its intention to grant, a permit under that Act.

(2) Without prejudice to the generality of subsection (1), conditions may be imposed on the grant of permission to develop land thereunder-

for regulating the development or use of any land under the control of the applicant (whether or not it is land in respect of which the application was made) or requiring the carrying out of works on such land, so far as appears to the local planning authority to be expedient for the purposes of or in connection with the development authorized by the permission;

- (3) Provision may be made by a development order for regulating the manner in which applications for permission to develop land are to be dealt with by local planning authorities, and in particular
- a. for enabling the Minister to give directions restricting the grant of permission by the local planning authority, during such period as may be specified in the directions in respect of any such development, or in respect of development of any such class, as may be so specified
 - b. for authorizing the local planning authority, in such cases and subject to such conditions as may be prescribed by the order, or by directions given by the Minister thereunder, to grant permission for development which does not appear to be provided for in the order or in any plan or statement deposited with the order and is not in conflict therewith;
 - c. for requiring the local planning authority, before granting or refusing permission for any development, to consult with such authorities or persons as may be prescribed by the order or by directions given by the Minister thereunder;
 - d. for requiring the local planning authority to give to any applicant for permission, within such time as may be prescribed by the order such notice as may be so prescribed as to the manner in which his application has been dealt with;
 - e. for requiring the local planning authority to furnish to the Minister and to such other Persons as may be prescribed by or under the order, such information as may be so prescribed with respect to any application for permission made to them, including information as to the manner in which such application has been dealt with.
 - f. Every local planning authority shall keep, in such manner as may be prescribed by the development order a register containing such information as may be so

prescribed with respect to applications for permission made to such authority, including information as to the manner in which such applications have been dealt with; and every such register shall be available for inspection by the public at all reasonable hours.

Applications to determine whether permission required

14.-

- (1) If any person who proposes to carry out any operations on land or make any change in the use of land wishes to have it determined whether the carrying out of those operations or the making of that change in the use of the land would constitute or involve development of the land within the meaning of this Act, and, if so, whether an application for permission in respect thereof is required under this Part having regard to the provisions of the development order, he may, either as part of an application for such permission, or without any such application, apply to the local planning authority to determine that question.
- (2) The foregoing provisions of this Part shall, subject to any necessary modifications, apply in relation to any application under this section and to the determination thereof as they apply in relation to applications for permission to develop land and to the determination of such applications.

3.3.5 *The Public Health Act, 1985*

This Act falls under the ambit of the Ministry of Health (MOH) and governs all matters concerning the handling of food material. In addition, provisions are also made under this Act for the activities of the environmental control division (ECD), a division of the MOH. The ECD's functions include:

- The monitoring of waste water quality,
- Monitoring of occupational health as it relates to industrial hygiene of potentially hazardous working environments

This Act has been consulted for the proposed cable lay.

3.3.6 The Jamaica National Heritage Trust Act, 1985

The Jamaica National Heritage Trust, formerly the Jamaica National trust, administers the Act. This Act provides for the protection of important areas, including the numerous monuments, forts, statues, and buildings of historic and architectural importance in Jamaica.

This Act will prove applicable if any structures of archaeological and/or architectural importance are located on the site, affected by the site activities or unearthed during site activities. Since this project is in an area that may contain items of archaeological importance, an Archaeological Retrieval Plan is included as part of this document.

3.3.7 The National Solid Waste Management Authority Act, 2001

The National Solid Waste Management Authority (NSWMA) under this Act has the responsibility to manage and regulate the solid waste sector. It includes requirements for licences for operators and owners of solid waste disposal facilities (in addition to permit requirements of NEPA).

Fibralink will utilise existing, approved industrial landfill sites for all solid waste generated from this proposed project. Fibralink will also practice recycling as much as possible of the materials used within its operation.

3.3.8 Draft National Building Code for Jamaica, 2007

The decision to review and revise Jamaica's building codes, which has taken almost four years, was in keeping with the guiding principles for the development of standards as enshrined in the World Trade Organisation's Technical Barriers to Trade Regulations and Annex dealing with the Code of Good Practice for the Development of standards.

These principles speak to use of international standards as the basis for developing national standards, require the inclusion of all interested parties and partners in the standards development process; demand that this process be carried out with openness and transparency at all stages of development and that the final documents be approved on the basis of consensus. This document is still in the draft stage.

Jamaica currently uses the codes based on the International Building Code (IBC) published by the International Code Council (ICC) USA since 2000, which is currently being used by various other countries in the English-speaking Caribbean.

These standards will be governed under the Town and Country Planning Act and be regulated by the Parish Councils.

This project will conform to all applicable building codes as mandated by the Parish Council and other relevant agencies.

3.3.9 *St. Thomas Parish Development Plan,*

There are no development plans currently in effect for the Parish of St. Thomas. The St. Thomas Parish Council is currently planning to develop a development order to ensure the future development of the parish¹. Development of the Parish is currently through the Parish Development Committees.

3.4 International Policy

3.4.1 *Agenda 21*

Jamaica is signatory to the convention (Agenda 21) which came out of a United Nations hosted conference on the Environment and Development, held in Rio de Janeiro in June 1992 (EARTH SUMMIT '92). Twenty-seven (27) environmental principles were outlined. Not all these principles are applicable to the project, but those deemed relevant and appropriate are outlined below:

Principle 1 Human beings are at the centre of concerns for sustainable development. They are entitled to a healthy and productive life in harmony with nature.

Principle 3 The right to development must be fulfilled to equitably meet developmental and environmental needs of present and future generations.

¹ <http://www.jamaica-gleaner.com/gleaner/20070204/lead/lead5.html>

Principle 4 In order to achieve sustainable development, environmental protection shall constitute an integral part of the development process and cannot be considered in isolation from it.

Principle 10 Environmental issues are best handled with the participation of all concerned citizens, at the relevant level, each individual shall have appropriate access to information concerning the environment that is held by public authorities, including information on hazardous materials and activities in their communities, and the opportunity to participate in decision-making processes. States shall facilitate and encourage public awareness and participation by making information widely available. Effective access to judicial and administrative proceedings, including redress and remedy, shall be provided.

Principle 11 States shall enact effective environmental legislation, Environmental Standards, management objectives and priorities should reflect the environmental and developments context to which they apply.

Principle 15 In order to protect the environment, the precautionary approach shall be widely applied by States according to their capabilities. Where there are threats of serious or irreversible damage, lack of full scientific certainty shall not be used as a reason for postponing cost-effective measures to prevent environmental degradation.

ANALYSIS OF ALTERNATIVES

4 Analysis of Alternatives

4.1 Introduction

4.2 No-Action Alternative

The proposed submarine fibre-optic cable would not be installed. No operations and maintenance activities would occur. This alternative would not fulfil the purpose of the project or meet the identified needs for high-speed data transmission in the eastern section of Jamaica. The redundant capabilities of the system would not be put in place which would result in loss of service should the existing system be damaged. Also, Jamaica would not realise the potential connection to South America which has become a major trading partner. The enormous economic and social development opportunities for Information Communication Technology (ICT) as well as the investment will be lost, including the potential for job creation. It therefore would be necessary to consider alternative methods of meeting data transmission requirements.

4.3 Landing Site Alternatives

The proponent also considered a number of alternate landing sites along the South-east coasts of the island. The landing sites were selected based on a number of factors. Of primary concern was the type and degree of impact the cable installation would have on the coastal and marine ecology. The sites that are proposed in this report represent the best selections from exhaustive considerations of a number of sites. Some of which were disqualified on the basis of:

- Estimated coastal and marine ecological impacts,
- Distance to existing or proposed hubs,
- Impacts to and on cable laying installation, and
- Through consultations.

4.3.1 Bull Bay, St Andrew Alternatives

The new landing site to offer redundant capabilities was chosen within the immediate region of the existing landing. The coastline within the 1 km - 4 km distance to the east of the Bull Bay landing was considered ideal for the new landing site. West of the existing landing site would propose landing with the Port Royal Protected Area. This direction was rejected on this basis.

The areas targeted were those where the main road was relatively close to the shoreline and in organized developments with fishing activity limited to small boat (canoe type) boats with nets, trawl and spear fishing and little or no apparent vessel anchoring.

The two areas evaluated are as follows:

1. Copacabana; 17° 56.571'N, 076° 41.478'W
2. New Little Copa Club; 17° 56.553'N, 076° 41.379'W – **Preferred Alternative**

The New Little Copa Club landing site in Bull Bay is within reach of the existing cable landing site with the necessary infrastructure already in place (cable housing building), with well defined ownership and property details.

The other site considered within the immediate region was Copacabana, approximately 1.6 km east of the existing Fibralink cable station. Both sites share a coarse sand beach that deepens slowly without any reefs present. It is similar to the existing Bull Bay approach which is mainly coarse sand and small boulders without any coral present. Both these sites provide excellent access for shore end activities.

The distance from the main road, along the community roads, to the proposed Nearshore manhole is approximately 230 m, a longer distance in comparison to the New Little Copa Club site which is 75 m. The elevation is approximately 3 m compared to New Little Copa Club which is at 4.5 m above sea level. However, the proposed manhole location is an area that has been designated as a community park. Also, the New Little Copa Club site has lower backhaul costs.

4.3.2 Prospect - Morant Point, St Thomas Alternatives

The coastline along this area has primarily shallow water less than 6 m water depth to a distance from the shoreline varying from approximately 50 m – 300 m with breaking waves on the seaward side where the depth appears to increase dramatically. This is indicative of coral reefs in the area of the breaking waves for the area and was confirmed through dive surveys. However, the charts indicated a deeper water channel between these reefs at Morant Point, the bottom of which was found to consist mainly of sand.

This entire area is within a developing community, Prospect, which can be described as organized middle/low income, with fishing activity limited to small boat (canoe type) boats with nets, trawl and spear fishing and little or no apparent vessel anchoring.

There were three areas that were closely evaluated:

1. Ocean View Close; 17° 51.865'N, 076° 20.450'W – **The Preferred Alternative**
2. Windy Way; 17° 51.818'N, 076° 20.403'W
3. Tuna Drive; 17° 51.610'N, 076° 20.346'W

All sites provide excellent access for shore end activities.

Windy Way and Tuna Drive have rugged coral shorelines unlike Ocean View Close which has a sandy shore and a gentle slope from shore to the channel. The water depth at the shoreline is approximately 1.2 m for a distance of approximately 10 m for all three sites where it drops into the sandy channel noted above except for Tuna Drive. The manhole location for all three sites is approximately 1.5 m above sea level and 10 m from the shoreline. The distance to the proposed cable station site is 820 m for Windy Way, 600 m for Ocean View Close and 1.4 km for Tuna Drive. Windy Way requires a direction bore of approximately 150 m – 180 m, less than that for Ocean View Close, with Tuna Drive requiring more. The right-of-way option for Ocean View Close provided better solutions for the project. Also, the channel at Ocean View Close provides some protection against heavy seas from the south which is not offered by the other sites.

4.4 Technology Alternatives

The proponent evaluated a number of technological alternatives that either did not fulfill the purpose of the project or did not meet agreed criteria. The major factors that affected the acceptability of those options were potentially adverse environmental effects and problems related to technical feasibility. The following details the advantages of incorporating a high speed data fibre-optic cable in Jamaica, when compared with other technologies outlined below:

- **SPEED:** Fibre optic networks operate at high speeds - up into the gigabits
- **BANDWIDTH:** large carrying capacity

- **DISTANCE:** Signals can be transmitted further without needing to be "refreshed" or strengthened.
- **RESISTANCE:** Greater resistance to electromagnetic noise such as radios, motors or other nearby cables.
- **MAINTENANCE:** Fibre optic cables costs much less to maintain.

4.4.1 *Radio*

Other high-speed wireless providers, such as those using 24 GHz, 28 GHz and 38 GHz spectrum, have concentrated on the more densely populated urban areas because of transmission distance limitations. Signals using these radio frequencies are generally limited to a one to three-mile radius, or three to 28 square miles, which makes application in less densely populated areas less economical. These frequencies are inherently more susceptible to weather and environmental interference.

4.4.2 *Telephony*

The telephone industry predominantly uses copper twisted-pair for the delivery of communications services to commercial and residential customers. Plain old telephone systems have been the primary means of communicating both locally and long distance. The problem is that it was designed for the transmission of voice communications. It's a mature technology, but inadequate by design, the amount of bandwidth that can be delivered is restricted by the characteristics of the copper twisted-pairs installed between the customer and central office.

Fibre-optics spans the long distances between local phone systems as well as providing the backbone for many network systems (such as cable television services, university campuses, office buildings, industrial plants, and electric utility companies).

The main difference is that fibre-optics use light pulses to transmit information down fibre lines instead of using electronic pulses to transmit information down copper lines.

Services such as DSL delivered across a local exchange carrier's existing copper wire system are capable of delivering very high speeds. However, DSL suffers performance limitations based on the distance from the customer premises to the serving central office. Distances are limited to about four to five miles from a central office for the lowest speed solutions and 10,000 feet or

less for the fastest. Additionally, much of the plant is physically incapable of providing broadband service.

4.4.3 *Satellite Data Transmission*

The proponent evaluated a non-cable option of replacing the proposed telecommunication and data transmission services with satellite communications. The use of communications satellites to provide the services identified as necessary would require no construction in the marine environment, but would not provide the capacity or quality of service proposed under the project.

Satellite networks, such as direct broadcast satellite, currently offer only one-way Internet access. Upstream access is limited to existing copper telephone lines. Other alternatives like Low Earth Orbit (LEO) Satellite Systems are not scheduled to be completed for years and have not proven capable of providing "carrier-class" voice or data services. Fibre optic cables transmit voice and data traffic with higher reliability and security at a cheaper rate than satellite. While a satellite call must travel 27,000 miles (35,780 km) from the earth to the satellite and then another 27,000 miles back, a Jamaica to Florida fibre optic call need only travel about 200 miles point-to-point. At the speed of light this helps to eliminate the delays suffered during a satellite telephone call.

The option does not meet the purpose of the project.

DESCRIPTION OF THE ENVIRONMENT

5 Description of the Environment

5.1 Physical Environment

5.1.1 Meteorology

While there are variations in the weather patterns along the south coasts of the island, it is not envisioned that any of the parameters assessed in this section will have any negative impacts on the establishment, operation or maintenance of the project.

Ideally, one should obtain data for weather and meteorological parameters from stations within the defined boundaries of the region in which an assessment is being made. The following subsections outlines the parameters used for assessment:

5.1.1.1 Climate

5.1.1.2 Rainfall

The project area is located along the south-eastern coast of Jamaica, which is characterized by low and/or sporadic rainfall patterns during the course of the year. This region is shielded by the John Crow Mountain and Blue Mountain ranges from the North-easterly trade winds which enter the island. This shielding effect results in the rapid condensation of the wind currents as they come off the mountain ranges, causing reduced precipitation as they flow into the Southern part of the island. This causes the above stated low and/or sporadic rainfall with not much overcast conditions being experienced.

Typical of coastal regions is the effect of land and sea breeze, in which there is an expected gentle moist breeze coming on-land from the sea during the course of the day, and a gentle breeze flowing off-land to the sea during the night time. This event is a characteristic of the thermal properties of both the land and the sea and would not significantly affect weather in a general way.

The nature of this project, from construction through to operation dictates that the weather regime experienced in this area, will not have any impact on this project.

Figure 5-1 and Figure 5-2 below shows the average annual rainfall figures for the Palisadoes and Morant point. These represent the closest available data points provided by the Meteorological

Office of Jamaica. Bull Bay experiences less than 150 mm of rainfall annually, whereas Prospect experiences less than 270 mm of rainfall per year.

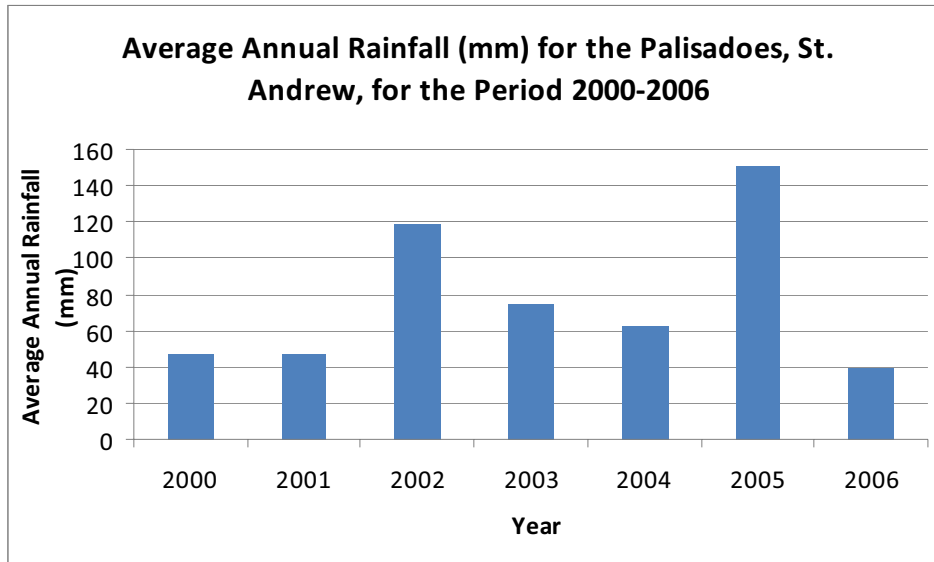

Figure 5-1: Average Annual Rainfall for the Palisadoes, St. Andrew, 2000-2006

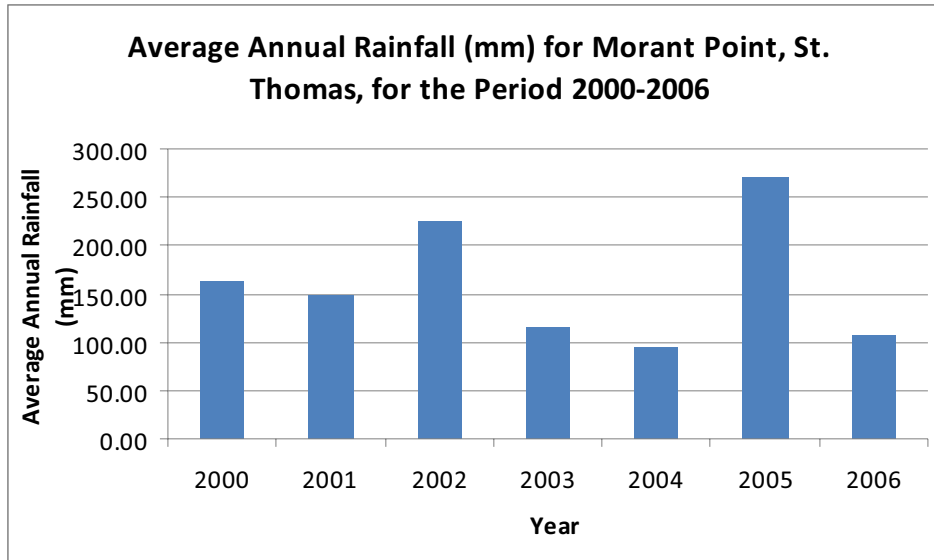

Figure 5-2: Average Annual Rainfall for Morant Point, St. Thomas, 2000-2006

5.1.1.3 Wind

The daily wind pattern across Jamaica is dominated by the Northeast Trade Winds. During the day on the South Coast, the sea breeze combines with the Trades to give an east-southeasterly wind with an average speed of 18 knots (21 miles per hour). In the period December to March, however, the Trades are lowest and the local wind regime is a combination of trades, sea breeze,

and a northerly or northwesterly component associated with cold fronts and high-pressure areas from the United States.

During the night, the trades combine with land breezes which blow offshore down the slopes of the hills near the coasts. As a result, on the South Coast, nighttime winds generally have a northerly component with a mean speed of 7 knots (8 miles per hour). By day, from June to July, mean onshore winds often reach a maximum of up to 26 knots (30 miles per hour) along the South Coast during mid-afternoon.

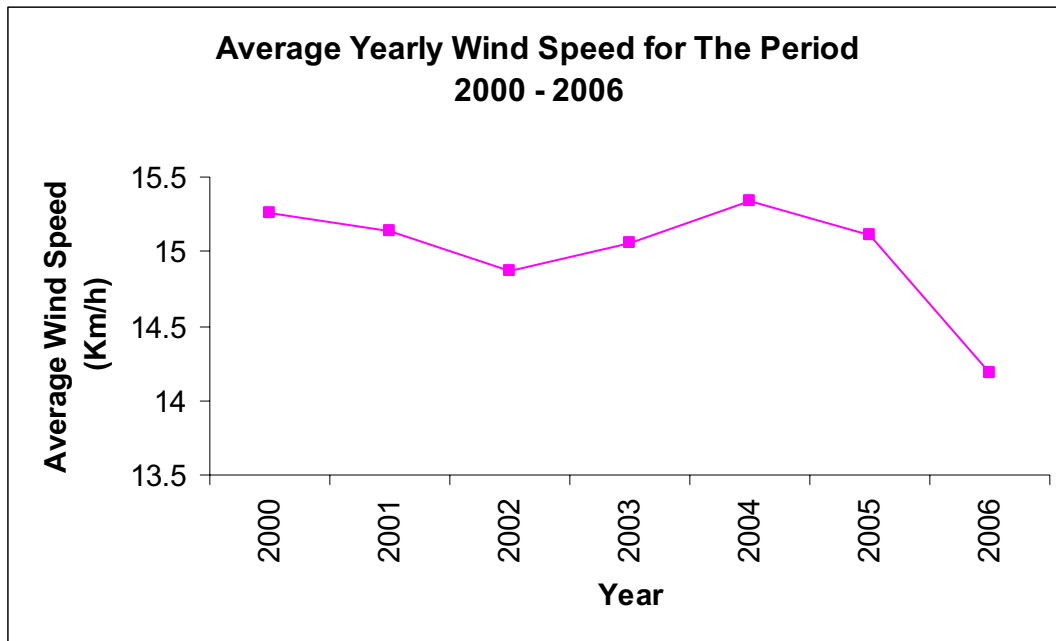

Figure 5-3: Average Wind Speed per Year along the South-East coast of Jamaica, 2000-2006

5.1.1.4 Weather Impact on Project

While there are variations in the weather patterns between the north and south coasts of the island, it is not envisioned that any of the parameters assessed in this section will have any negative impacts on the establishment, operation or maintenance of the project.

5.1.2 Hydro- and Geophysical Environment

5.1.2.1 Geology

5.1.2.1.1 Bull Bay, St. Andrew

Elevations at the site increase gently from sea level along the shoreline to a maximum of 1.5 metres above sea level along the boundary with the Bull Bay to Kingston main road, in the vicinity of Seven Miles. The area is underlain by alluvium terraces and the August Town Formation. The river terraces are detritus from the Hope and other rivers that drain the area. The August Town Formation is of Pliocene age and is the Lower Coastal Group and consists of yellowish sandy marls and limestone rich in fossils.

The soil at the shoreline is dark silty-sand overlaid by coarse and smooth pebbles. The potential for erosion of soil materials during periods of moderate to heavy rainfall at the site is minimal as the area continuously undergoes strong wave action and is fairly stable.

Along the beach, the substrate depth ranged from 0 cm to 10 cm, and consists of coarse, angular, highly sorted carbonate sand grains with large pieces of coralline material along with the numerous varied sized pebbles. This suggests recent (less than 50 years) storm surge deposits (possibly from Hurricane Ivan in September 2004). Sediments on the sandy shore are composed of typical dark sand grains as seen on Jamaica's south coast.

It is not perceived that the present topography and geology of the site requires any special considerations prior to a development such as the one proposed being implemented.

The inshore has a relatively, consistent declining slope substrate of dark sand from near shoreline to about 460 m offshore. The area is made-up of soft sandy substrate. There is no coral reef substrate along the survey path or rocky outcroppings.

5.1.2.1.2 Prospect, St. Thomas

Elevations at the site increase gently from sea level along the shoreline to a maximum of 2 metres above sea level at the end of Ocean View Close. The community of Prospect (along the Kingston to St. Thomas main road) the elevation is approximately 10 m. The Prospect area is underlain by the coastal limestone of the White Limestone Group. The limestone patchily fringes the coast and consists of soft marls. Thickness approaches 30 metres.

The soil at the shoreline is white sand with few smooth pebbles. The potential for erosion of soil materials during periods of moderate to heavy rainfall at the site is minimal. The shoreline is fairly stable due to the sheltered bay and the coral reef and seagrass beds that offer it protection. The surrounding lands are vegetated and offer protection landwards.

Along the beach, the substrate depth ranged from 0 cm to 10 cm, and consists of sorted carbonate sand grains with small pieces of coralline material. Sediments on the sandy shore are composed of typical white sand grains.

It is not perceived that the present topography and geology of the site requires any special considerations prior to a development such as the one proposed being implemented.

The inshore has a relatively, consistent declining slope substrate of white calcareous sand from near shoreline to 1000 m offshore. The area is made-up of soft sandy substrate. Though a small fringing coral reef is in close proximity, the route alignment proposed will not infringe on this important ecosystem as it will be laid on the sandy channel bottom.

5.1.2.2 Hydrology

The formations are classified as aquicludes i.e. it does not transmit water and does not yield water readily to wells and springs. There is no potential for water resources development at Bull Bay.

The limestone is classified as an aquiclude i.e. it does not transmit water and does not yield water readily to wells and springs. Wells drilled at Prospect by the National Water Commission (NWC) were very low producers and have been abandoned. There is no potential for water resources development at Prospect.

Figure 5-4 below outlines the hydrostratigraphic map of St. Thomas showing the two sites.

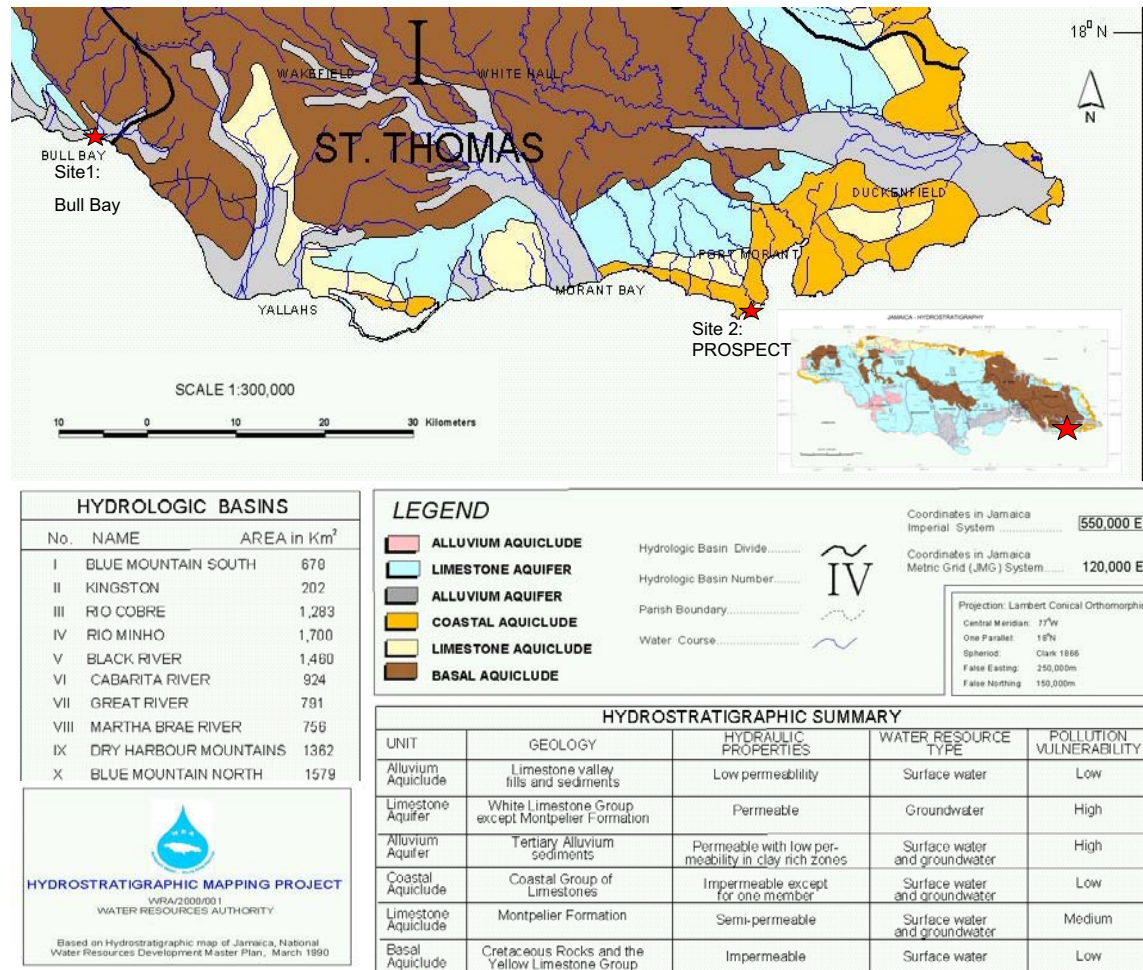

Figure 5-4: Hydrostratigraphic Map showing the two sites: Bull Bay and Prospect²

² Extracted from the Hydrostratigraphy Map of Jamaica provided by *The Water Resources Authority (WRA)*, Jamaica

5.2 Hazard and Risk Assessment

The proposed project consists of two concurrent operational phases:

1. An offshore operational phase.
2. An onshore operational phase.

The components of both phases will set the baseline for the operation of the proposed cable infrastructure, and therefore must be considered when estimating the vulnerability of the proposed infrastructure to nature. The operational infrastructure has the potential to be affected, to some degree, by existing climatic and potential weather patterns, geological activity (specifically tectonic activity) and the hydrostratigraphy (especially in relation to flooding potential) of the various regions where cable installation and laying is proposed to occur. For the purposes of this Marine Assessment offshore consideration will be given only up to the boundary of the Jamaican coastal waters – beyond that is beyond the jurisdiction of this assessment, however, if necessary, references to any pertinent and appropriate similarities in the region will be incorporated.

5.2.1 Offshore Cable Operations

The offshore cable operational phase is slated to occur in two distinct phases:

1. Deep-shore operations
2. Near shore operations (this is a transition into the onshore cable operational phase.)

Common to both phases is the medium of operation (water) and, as such, are likely to be affected by wave action that is generated from aggressive deep water movement, which is caused by storm surges and tectonic activity. Extreme occurrences of either of these events could cause unlikely cable failure through abrasion and or instantaneous or gradual extension of the cable beyond the elastic limits of its component materials. However, as with every event, there is a threshold required for noticeable occurrence and also a limit at which the event will cause unfavourable results; therefore, it is arbitrary to assume that any storm surge or tectonic activity will cause any cable unlikely failure. Although there is no pragmatic way to define exactly what level of displacement in the sea floor (vertical and horizontal) or what type of storm surge will generate a certain definable stress on the cable, it is statistically possible to conclude from Table 2-3 that both abrasion and tectonic activity rarely causes cable failure. Implicit in the data, is the

fact that these events rarely generate the forces required to exceed the limits of the cable materials' strength. Therefore, one can assume that the combined material strength of the cable materials have been designed to withstand common abrasion forces resulting from water movement, and the effects of common minor plate movement. Keep in mind that there are miles of this type of cable deployed worldwide under a wide variety of marine and seismic conditions that are fully functional.

The deep shore aspect of the cable operations can be generally regarded as unaffected by storm surges. Storm surges do not usually disturb the ocean bottom in deep waters by virtue of deep water depth in relation to the volume of water that is displaced. However, pronounced effects are estimated as likely for near-shore operations as the cable makes the transition to onshore operations. However, as stated earlier, it is difficult to correlate storm surge magnitude with sustainable cable integrity – one can only assume that cable breakage is unlikely to occur due to the design and established track record of the industry. Cable breakage is unlikely in and of itself to result in environmental degradation or negative environmental impacts.

5.2.2 Onshore Cable Operations

The onshore cable operation has two (2) distinct areas of operation:

1. Onshore shelter station where data relay is done
2. Terrestrial areas:
 - a. Above ground, along existing electrical high tension wires
 - b. Underground, on route to installation or relay areas

Given the degree and frequency of seismic activity in Jamaica (See Section 5.2.3 below), seismic activity is not expected to generally affect either the terrestrial areas or the on-shore shelter station area in a critical way. Further, it is assumed that existing infrastructure would have been approved for construction with considerations being given to flooding vulnerability, land slippage vulnerability and seismic activity. Hence, given the relationship between existing infrastructure and the proposed cable network, the hazard vulnerability, in the above mentioned regards, will depend largely on the approved infrastructure, in which the cable and associated equipment are housed.

Of considerable concern is the potential effect of storm surge on the on-land shelter station which houses the electronic equipment for data relay. Effects from flooding and battering due to these storm surges could pose problems for both the electronic equipment and the building's structural integrity. Therefore, the building has been designed to be at a proposed height of more than 3m above sea level, which is estimated to give it sufficient clearance from storm surge activity. Regardless, the terrain of the sites is estimated to substantially exceed this proposed minimum requirement. It is not anticipated that even if the buildings and equipment were to be damaged by natural hazards that it would result in a negative environmental impact.

5.2.3 Seismic Vulnerability

Jamaica lies in the seismically active northern plate boundary zone of the Caribbean Plate (Draper et al., 1994 and Figure 5-5). High magnitude earthquakes originating from as far away as the south coast of Cuba may be felt in Jamaica. For example the Cabo Cruz earthquake of magnitude 6.9 which occurred in May 1992 was felt with intensity 4 in Kingston, Jamaica. The 1993 earthquake of magnitude 5.4 which originated in Jamaica was felt in Cuba with intensities of 3-4. No damage was reported in either case from the distant country (pers. comm. M. Grandison).

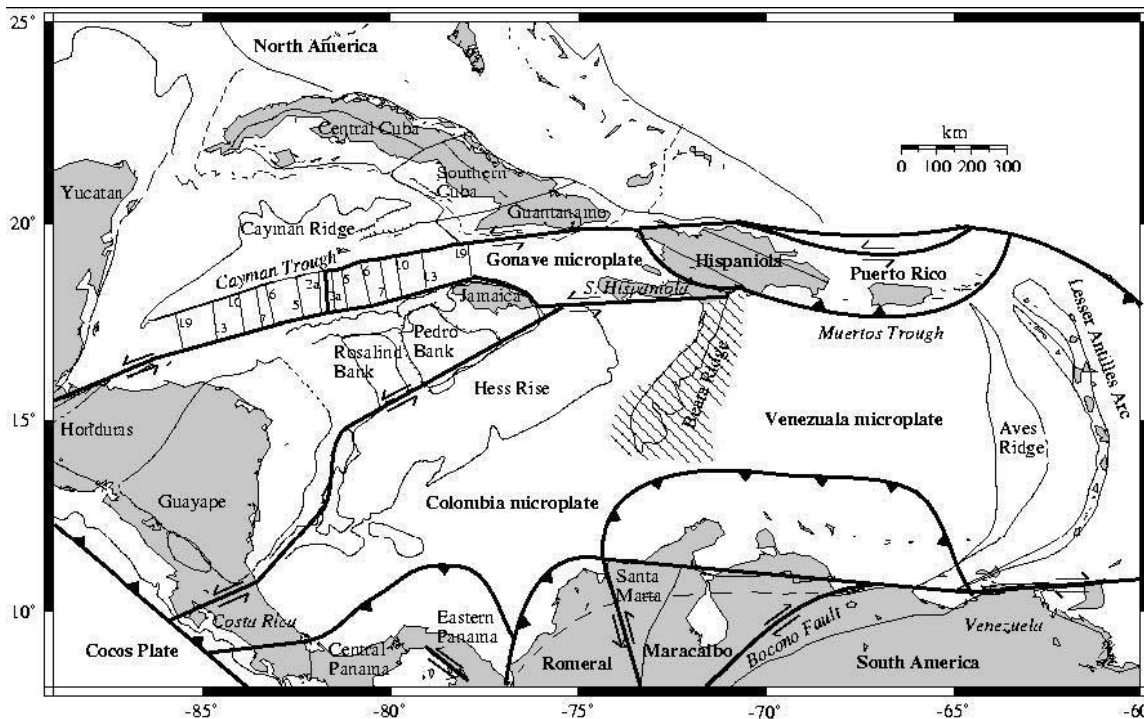

Figure 5-5: Tectonic Plates in the Caribbean region

Figure 5-6 shows the epicentres of over one-hundred (100) earthquakes which have occurred in or near Jamaica between 1998 and 2001. With over 100 such occurrences, there was no significant damage to any approved infrastructure within the island to warrant consideration for the adjustment or revision of any building or construction codes for the island.

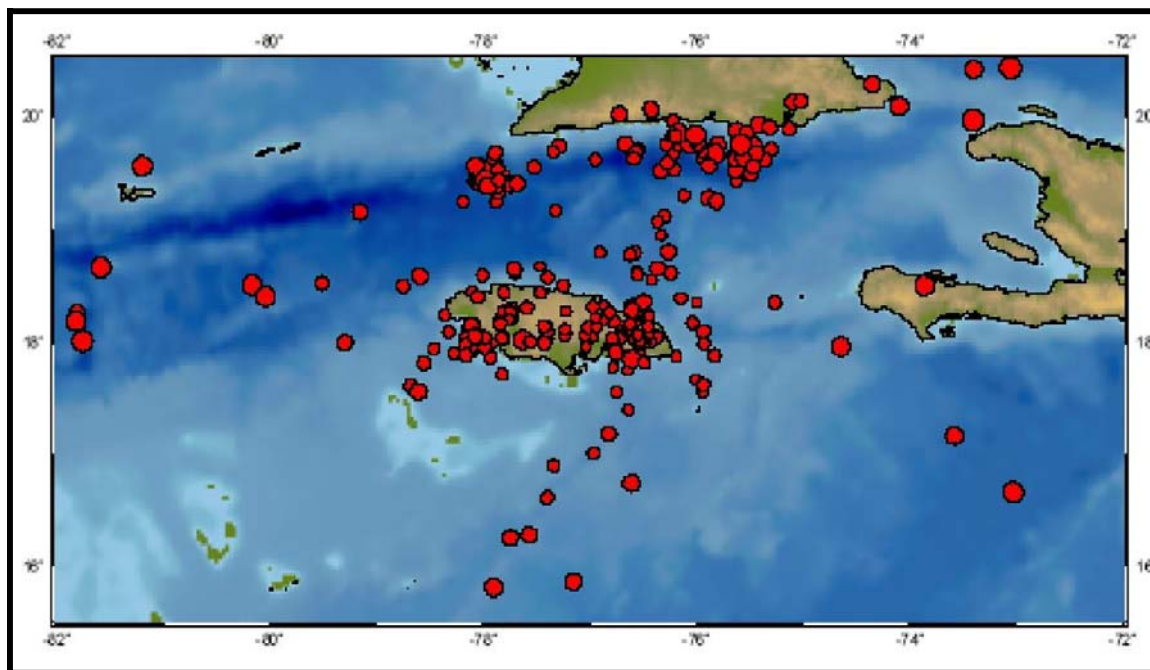

Figure 5-6: Epicentres of Earthquakes Occurring Between 1998 and 2001 In The Vicinity Of Jamaica³

Figure 5-7, Figure 5-8, and Figure 5-9 are summarized in Table 5-1 in relation to the proposed coastal landing sites. Table 5-2 allows one to conceptualize the type of effect the predicted values in Table 5-1 are likely to have. In analyzing Table 5-1, it becomes evident the most seismically active of all three sites is that of the Bull Bay site. As such, this site may be used as reference for the expected worst case scenario for any seismic activity which may be experienced by both sites. From Table 5-1, it is expected that that there is only a 10% probability of any earthquake which occurs in or is felt by the Bull Bay area to exceed an intensity of 8 (VIII) within a 50 year period. An earthquake of such intensity is not likely to damage, or sufficiently damage buildings designated as *Masonry A* or *Masonry B* type construction (Table 5-2). This is significant because most buildings in Jamaica are designed to one of the two Masonry types mentioned above – the proposed onshore shelter station is no different (See Figure 2-8). Further inspection of Table 5-2 reveals that earthquakes of such intensity are not likely to cause damage

³ Source: *Earthquake Unit, University of the West Indies, Mona*

to underground pipes or disrupt their orientation significantly. The cables that will have to be laid underground are of greater strength and flexibility than conventional underground pipes, and do not transmit volatile or heavy fluids, whose dynamics or reactions might produce further stress on the pipes during an earthquake. Therefore, they are less likely to break under similar stress and strain conditions than the conventional underground pipes discussed in Table 5-2. Therefore, given the degree and frequency of seismic activity in the Bull Bay area, it is evident that the installation of the cable system in this area will not be greatly threatened by seismic activity. Further, if one were to extrapolate in consideration of the other site, one could conclude that the Prospect site is less likely to be threatened by the same intensity of seismic activity as the Bull Bay site and is therefore less threatened by seismic activity.

It is important to note that the Bull Bay building site is an existing cable site that has been in existence long before the 1998-2001 period assessed during this project, and there has not been (to our knowledge) any record of cable failure due to seismic activity in the area.

Table 5-1: 10% Probability Exceedance in any 50 year Period of Three Earthquake Parameters for the Proposed Landing Sites

Landing Point	Horizontal Ground Acceleration /gals	Maximum Mercalli Intensity /MMI	Horizontal Ground Velocity /cms ⁻¹
Bull Bay, St. Andrew	270-295	>8	18-20
Prospect, St. Thomas	270-295	7-8	18-20

Table 5-2: Mercalli Scale⁴

Intensity	Effects	PGA*(gals)
I	Not felt. Marginal and long-period effects of large earthquakes.	less than 1
II	Felt by persons at rest, on upper floors or favourably placed.	1 - 2
III	Felt Indoors. Hanging objects swing. Vibration like passing of a light truck. Duration estimated. May not be recognized as an earthquake.	2 - 5
IV	Hanging objects swing. Vibration like passing of heavy trucks: or sensation of a jolt like a heavy ball striking the walls. Standing motor cars rock. Car alarms activated. Windows, dishes, doors rattle. Glasses clink, crockery clashes. In the upper range of IV wooden walls and frames creak.	5 - 10
V	Felt Outdoors. Direction estimated. Sleepers wakened. Liquids disturbed, some spilled. Small unstable objects displaced or upset. Doors swing, close open. Shutters, pictures move, pendulum clocks stop, start, change rate.	10-25

⁴ http://www.uwiseismic.com/Earthquakes/eq_monitoring.html#Anchor-MEASURIN-48543

Intensity	Effects	PGA*(gals)
Vla	Felt by all: many frightened and run outdoors. Persons walk unsteadily. Windows, dishes, glassware broken. Knickknacks, books etc. off shelves. Pictures off walls. Furniture moved or overturned. Weak plaster and masonry D cracked. Small church and school bells ring. Trees, bushes shaken (visibly or heard to rustle).	25-50
VII	Difficult to stand. Noticed by car drivers. Hanging objects quiver. Furniture broken. Damage to masonry D including cracks. Weak chimneys broken at roof line. Fall of plaster, loose bricks, stones tiles cornices unbraced parapets, and architectural ornaments. Some cracks in masonry C. Waves on ponds; water turned turbid with mud. Small slides and caving in along sand or gravel banks. Large bells ring. Concrete culverts damaged.	50-100
VIII	Steering of motor cars affected. Damage to masonry C: partial collapse. Some damage to masonry B, none to masonry A. Fall of stucco and some masonry walls. Twisting, fall of chimneys, factory stacks, monuments, towers, elevated tanks. Frame houses moved on foundations if not bolted down; loose panel walls thrown out. Decayed piling broken off. Branches broken from trees. Changes in flow or temperature of springs and wells. Cracks in wet ground and steep slopes.	100-250
IX	General panic. Masonry D destroyed; masonry C heavily damaged, sometimes with complete collapse; masonry B seriously damaged. General damage to foundations. Frame structures shifted off foundations if not bolted down. Serious damage to reservoirs. Underground pipes broken. Conspicuous cracks on ground. Sand boils, earthquake fountains, and sand craters.	250-500
X	Most masonry and frame structures destroyed with their foundations. Some well-built wooden structures and bridges destroyed. Serious damage to dams, dikes, embankments. Large landslides. Water thrown on banks of canals, rivers, lakes etc. Sand shifted horizontally on beaches and flat land. Rails bent slightly.	500-1000
XI	Rails bent greatly. Underground pipelines completely out of service.	**
XII	Damage nearly total. Large rock masses displaced. Lines of sight and level distorted. Objects thrown into the air.	**

Notes⁵:

* PGA is the effective Peak Ground Acceleration during the earthquake. That is the maximum horizontal ground acceleration excluding high frequency spikes. 1 gal = 1 cm/sec/sec. Since the intensity of gravity (g) is about 10 meters/sec/sec 10 gals is about 1% of gravity

** At the highest intensity levels damage potential is determined increasingly by the effects of ground failure. Most types of ground are unable to sustain prolonged accelerations much greater than 500 gals.

Masonry A. Good workmanship, mortar and design: reinforced especially laterally and bound together using steel, concrete etc. Designed to resist lateral forces.

Masonry B. Good workmanship and mortar. Reinforced but not designed in detail; to resist horizontal forces.

Masonry C. Ordinary workmanship and mortar. No extreme weaknesses like failing to tie in at corners but neither reinforced nor designed to resist horizontal forces.

Masonry D. Weak materials such as adobe; poor mortar; low standards of workmanship; weak horizontally.

(From Elementary Seismology by C.F. Richter, Published by W.F. Freeman and Company, San Francisco 1958)

⁵ http://www.uwiseismic.com/Earthquakes/eq_monitoring.html#Anchor-MEASURIN-48543

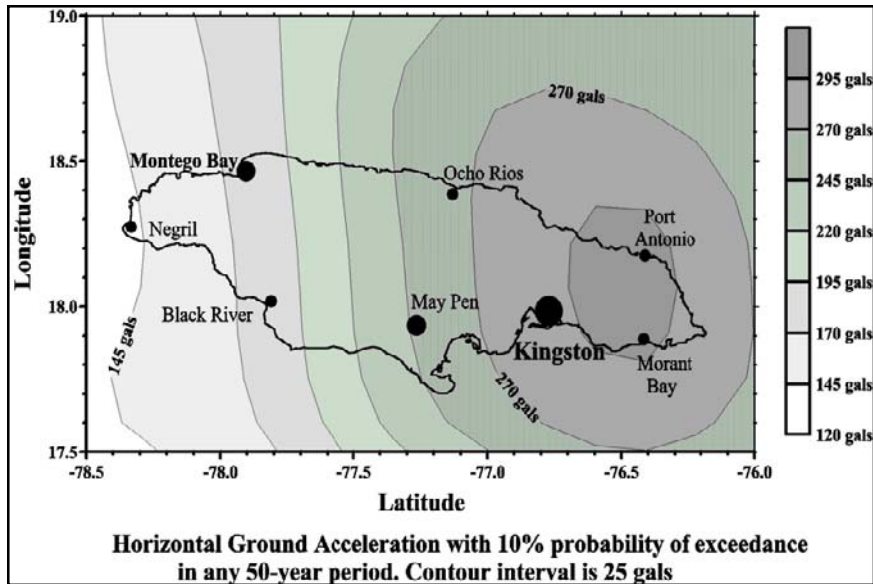

Figure 5-7: Horizontal Ground Acceleration in Jamaica⁶

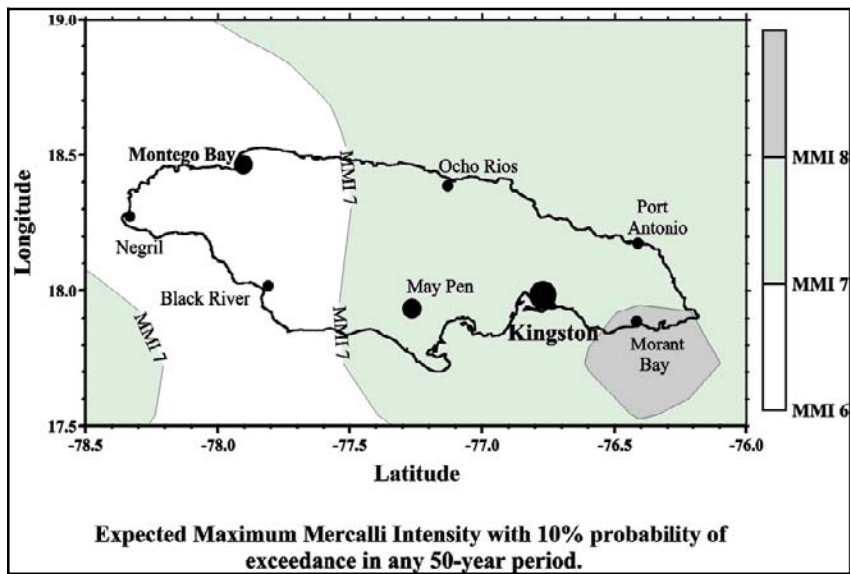

Figure 5-8: Maximum Mercalli Intensity in Jamaica⁷

⁶ <http://www.oas.org/CDMP/document/seismap/>

⁷ <http://www.oas.org/CDMP/document/seismap/>

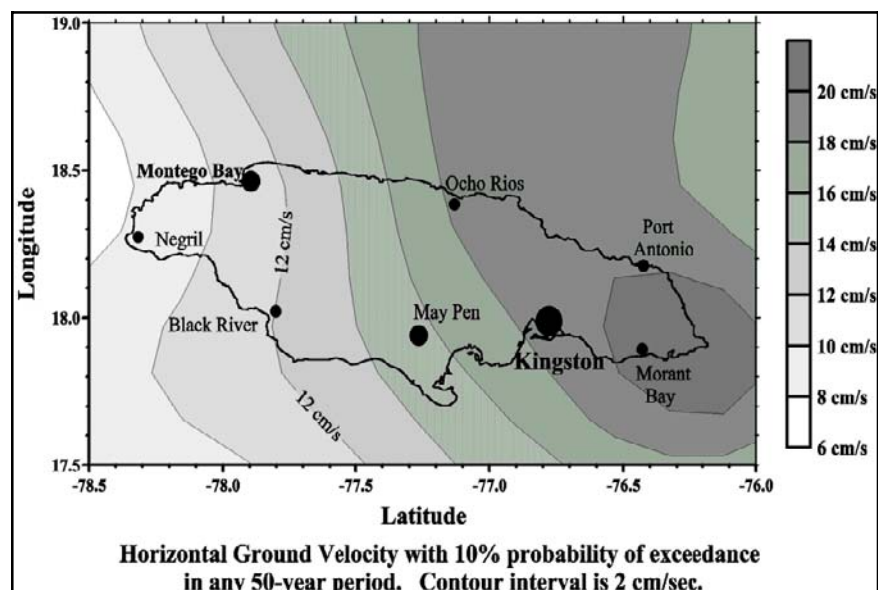

Figure 5-9: Horizontal Ground Velocity in Jamaica⁸

5.2.3.1 Landslide Vulnerability

Currently, the Mines & Geology division of the Land Services arm of the government has not generated Landslide Susceptibility maps for every parish of the island. Consequently, only one of the two areas proposed currently have any landslide vulnerability data available. Such information is currently available only for the Bull Bay, St. Andrew site; no accessible susceptibility maps have been generated for Prospect, St. Thomas.

A landslide is a natural disaster that cannot be definitely predicted or practically monitored during its occurrence; therefore one cannot be absolute in classifying an area in its susceptibility. In fact much of the classification process is done and defined through measurements which must be updated within a period that is discretionary and based on numerous factors. Landslides can be triggered directly and indirectly by things such as tectonic activity, rainfall, terrain alteration, geology, etc.

Landslides have the potential to affect every aspect of the fibre optic cable operation. Landslides can remove building foundations or simply swallow entire buildings. Therefore, it would be prudent to build the on shore shelter stations in areas that are not considered to be susceptible to the type of landslides which have such overwhelming and destructive capabilities. Landslides can also trigger wave action if there is an instant collapse of sections of the land into the sea. The

⁸ <http://www.oas.org/CDMP/document/seismap/>

degree of wave action varies across a spectrum of generic wave to mega tsunami, which depends on the amount of land mass which collapses instantly into the sea. Such events, however, are unlikely in Jamaica given the geology and the level of volcanic activity on the island. Landslides in this regard can affect the near shore operations of the cable system through these wave actions

Figure 5-10 shows the land slide susceptibility of parts of Kingston & St. Andrew. Geographically, the site termed Bull Bay is properly located in St. Andrew in the far South-eastern corner of the parish, bordering St. Thomas. According to Figure 5-10, the proposed project area has a low susceptibility to deep landslides, meaning that the probability of any occurrence of a deep landslide is anywhere between 0-0.02.

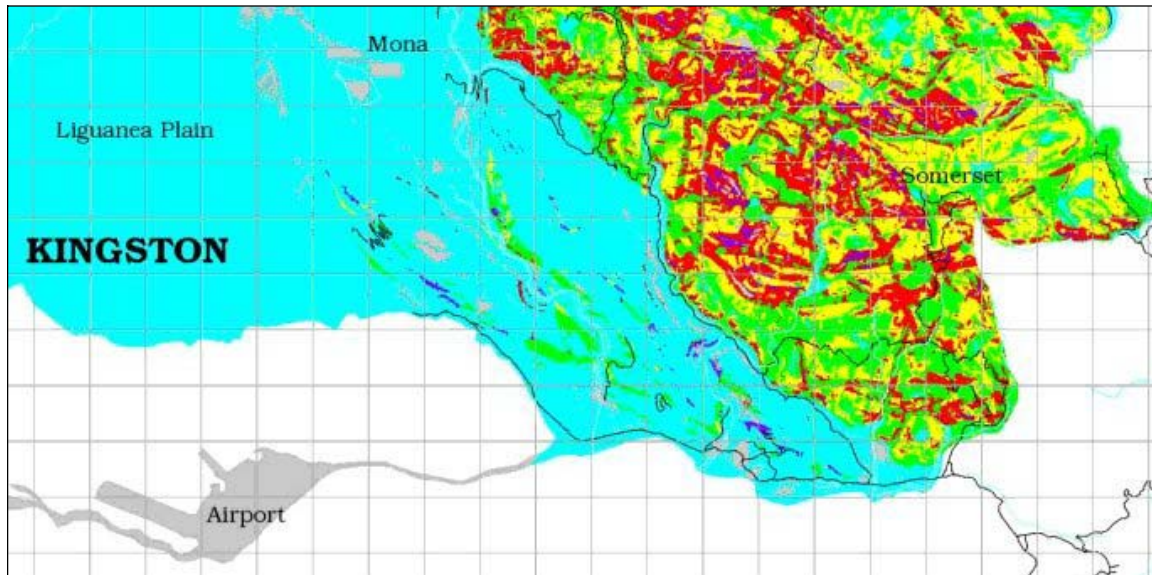

KEY

Non-Susceptibility
Low susceptibility (0-2%)
Moderate Susceptibility (2-3.5%)
Moderate-High Susceptibility (3.5-4.5%)
High Susceptibility (4.5-6%)
Very High Susceptibility (6-83%)

Figure 5-10: Land Slide Susceptibility Map for Bull Bay, St. Andrew Site⁹

⁹ <http://www.oas.org/CDMP/document/kma/landslmap.htm>

5.2.4 Hurricane Vulnerability

Generating the data commonly associated with storm activity, and the consequent probable trends, for each landing point of the island is not necessarily feasible or a pragmatic assessment given the scope of this Marine Assessment. However, an appreciable approach would be to consider a reference point on the island, namely the centre of the port of Kingston, and then use recorded cyclone activity over a period of time within the Caribbean region to estimate any associated trends related to the cyclone activity and the return period of such activities to the island¹⁰. This can be done confidently as Jamaica is a small island and is likely to be affected wholly regardless of the point of approach of a tropical depression or storm system.

Based on the values recorded in Table 5-3, Jamaica is estimated to have a 95% chance of experiencing, at the most, the wind speeds associated with a ‘*Category 1*’ hurricane every 10 years; and a similar chance of experiencing, at the most, the wind speeds associated with a ‘*Category 4*’ hurricane every 50 years.

Table 5-3: Kingston Central Port Wind Results (knots): Maximum Likelihood Estimates and Upper Prediction Limits for Various Return Periods (1 minute sustained wind at 10 meters above ground).¹¹

Return Period	MLE	50%	75%	90%	95%	99%
10 year	57	58.2	61.2	63.9	66.0	70.4
25 year	76	77.0	81.6	86.7	90.6	104.4
50 year	89	90.5	97.0	105.0	111.4	130.4
100 year	102	103.1	112.8	124.0	133.1	157.8

The MLE (maximum likelihood estimate) column provides the best estimate as to the mostly likely extreme one minute-ten meter sustained wind for the various time frames.

Consultation of Table 5-4 shows that, within a 10 year period, the maximum storm surge expected is approximately 3.4 m, and, within a 50 year period, the storm surge is unlikely to exceed 7.1 m. Therefore, if the proposed minimum height for the construction of the on-shore shelter station of 3 m above sea level is adhered to, the storm surge influence on the on-shore shelter station is not likely to occur in an overwhelming way, outside of a twenty-five year

¹⁰ **Organization of American States General Secretariat Unit for Sustainable Development and Environment USAID-OAS, Return Period Estimation of Hurricane Perils in the Caribbean**, Caribbean Disaster Mitigation Project April 1999

¹¹ **Organization of American States General Secretariat Unit for Sustainable Development and Environment USAID-OAS, Return Period Estimation of Hurricane Perils in the Caribbean**, Caribbean Disaster Mitigation Project April 1999

period. However, as stated earlier, the terrain of the sites is estimated to substantially exceed the proposed minimum requirement, it is also expected to exceed the maximum storm surge within 100 years (Table 5-4); hence storm surge is not an immediate area of concern. At all three landing sites the equipment building shares or exceeds the same elevation of the resort hotel’s residences and business establishments in their vicinity.

Table 5-4: Kingston Central Port Storm Surge Results (meters): Maximum Likelihood Estimates and Upper Prediction Limits for Various Return Periods¹².

Return Period	MLE	50%	75%	90%	95%	99%
10 year	2.737	2.758	2.958	3.122	3.193	3.397
25 year	3.848	3.897	4.193	4.519	4.791	5.505
50 year	4.693	4.714	5.157	5.636	5.932	7.112
100 year	5.539	5.586	6.136	6.941	7.542	8.777

Table 5-5: Kingston Central Port Wave Height Results (untransformed deep water significant wave height in meters): Maximum Likelihood Estimates and Upper Prediction Limits for Various Return Periods.¹³

Return Period	MLE	50%	75%	90%	95%	99%
10 year	7.1	7.2	7.5	7.8	8.1	8.9
25 year	8.9	9.1	9.6	10.3	11.1	14.8
50 year	10.2	10.3	11.0	11.9	13.1	18.0
100 year	11.5	11.6	12.6	14.0	16.0	22.3

¹² *Organization of American States General Secretariat Unit for Sustainable Development and Environment USAID-OAS, Return Period Estimation of Hurricane Perils in the Caribbean, Caribbean Disaster Mitigation Project April 1999*

¹³ *Organization of American States General Secretariat Unit for Sustainable Development and Environment USAID-OAS, Return Period Estimation of Hurricane Perils in the Caribbean, Caribbean Disaster Mitigation Project April 1999*

5.2.5 Flooding Potential

Assessing whether an area is prone to flooding or not, not only requires a hydrostratigraphic assessment of the area, but also the collection of physical data such as rainfall run-off patterns, topography and information obtained from actual flooding events (especially as perceived by individuals who reside or frequent the area during such events) over a statistically appreciable period. Such information is not readily available from relevant statutory agencies in a compiled an organized format and is beyond the scope of this Marine Assessment. However, broad conclusions may be drawn from what is available, including informal reports of flooding, or the absence thereof.

It is estimated that the project sites are located in areas where the soil are permeable to semi-permeable. Permeability or semi-permeability of the areas implies that water should percolate through the ground and drain into the underlying aquifers or aquicludes. Hence, in the absence of extreme weather conditions, namely heavy consistent and prolonged rainfall, the mentioned areas should not flood readily. Further, none of the sites are located in sink holes or areas of deep depression, therefore, issues related to runoffs from surrounding areas should not add to the flooding vulnerability of the areas to flooding.

There has been no specifically reported flooding for the Prospect area. The extent of flooding from a significant flooding event in 2001 for the Bull Bay area is seen in Figure 5-11, which is some distance from the proposed project site, and is not estimated to have had any significant effect on the proposed project site in that period. It should be noted that the project sites in Bull Bay is located on presently occupied properties, at an elevation of approximately 60 m above sea level, well above potential flood levels. None of two sites have reported issues of flooding.

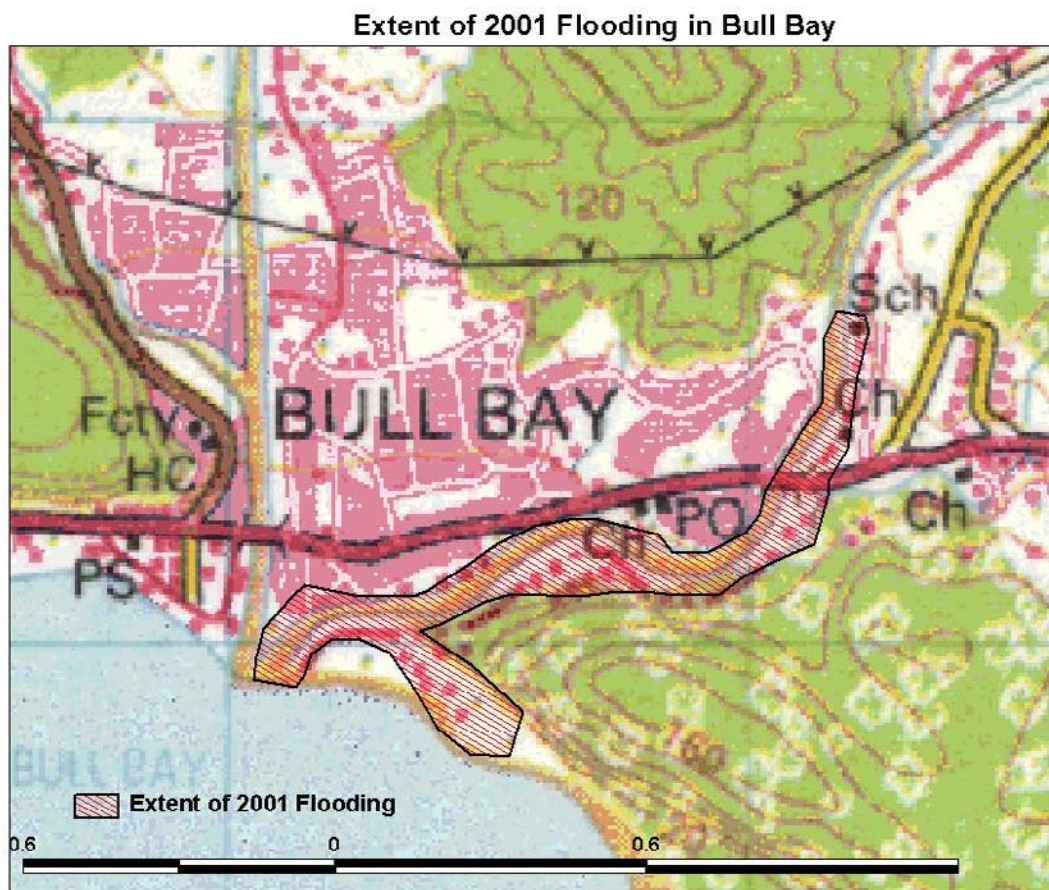

Figure 5-11 Extent of 2001 Flooding in Bull Bay¹⁴

5.2.6 Overall Assessment of Natural Hazard Vulnerability of Sites

Tremendous effort has been made by Fibralink to both identify and select cable routes and landing sites that will satisfy as best as possible the majority of areas of concerns associated with this project. As such, a lot of effort has been put into selecting routes that will have minimal impact on marine life and structures, land sites that will be limited in exposure and impact to natural hazards or have the potential to cause any major damage than the existing structures that will be in proximity to them.

All of the onshore facilities and sites have been designed to withstand hurricane force winds and sea conditions, thereby enabling the system to remain active during times when they are most needed. This includes the back-up power generation.

¹⁴ Courtesy of The Water Resources Authority (WRA), Jamaica

5.3 Biological Environment

5.3.1 Bull Bay, St. Andrew

The project site is located in a coastal area in an existing residential area and consists of the landing site and the cable housing. It is located just outside and to the east of the Port Royal Protected Area.

5.3.1.1 Marine Flora, Fauna and Habitats

A marine assessment was conducted along a corridor no more than 1 m wide; the cable is no more than 28.8 mm wide, of the marine environment. The marine assessment utilized dives of the area, video and still photography to document the condition of the seabed and associated structures and marine life in the study area. The depth of the assessment was up to a maximum of 18 m (60ft) which characterised the inshore.

The inshore has a relatively flat substrate of white calcareous sand from near shoreline to about 450-500 m where offshore distinction is made. This represents a depth of approximately 18 m (60ft). Based on the marine survey, the area is made of soft sandy substrate. It is accepted that various fishes (reef and otherwise) and other marine fauna may traverse the cable route. However, due to the nature of the cable laying activities and size of the cables being laid any interactions with marine fauna will be negligible. Of importance is the fact that no coral reefs lie in the path of the proposed cable route. There is no coral reef substrate along the survey path or rocky outcroppings.



Plate 5-1: Beach character [Note: retaining wall approximately 30 m from shoreline]

5.3.1.2 Wildlife Resources

The landing site is located on a strip of coastal land bordered by the sea on the south and the main road to the north. There are no trees or plants on the strip of beach; hence no nesting birds were seen in the area. Several marine bird species were observed such as gulls but none nest nearby or would be affected by cable laying activities on the seabed. No crab holes or crabs were observed.

5.3.1.3 Vegetation Resources

Landing Site - There is no vegetation community at the site. The site is a commercial property in close proximity to the main road. There are a few trees on the property but none that is considered endemic or rare, namely *Piscidia piscipula* (dogwood). The plant life is predominantly grasses at the road verge and eastern boundaries of the property and few invasive plant species such as *Antigonon leptopus* (Coralita).

Cable Housing Site - The cable house is to be sited at the existing AT&T facility which has manhole and underground conduits in place. As such, no disturbance of existing terrestrial community adjoining property is necessary. The cable will be routed from manhole at the landing site and taken via the road verge to the existing cable station.



Plate 5-2: View from the shoreline (Looking northwest)



Plate 5-3: New Little Copa Club Parking Lot



Plate 5-4: Vegetation at the New Little Copa Club

5.3.2 Prospect, St. Thomas

5.3.2.1 Marine Flora, Fauna and Habitats

Landing Site - A marine assessment was conducted along a corridor no more than 1 m wide. The marine assessment utilized dives of the area, video and still photography to document the condition of the seabed and associated structures and marine life in the study area. The depth of the assessment was in excess of 30 m (98.4 ft).

The seafloor within the study area could be described as a submerged carbonate platform, which appears to underlie loose and well bedded sedimentary deposits extending in depth from 5 m to 30 m (Figure 5-12).

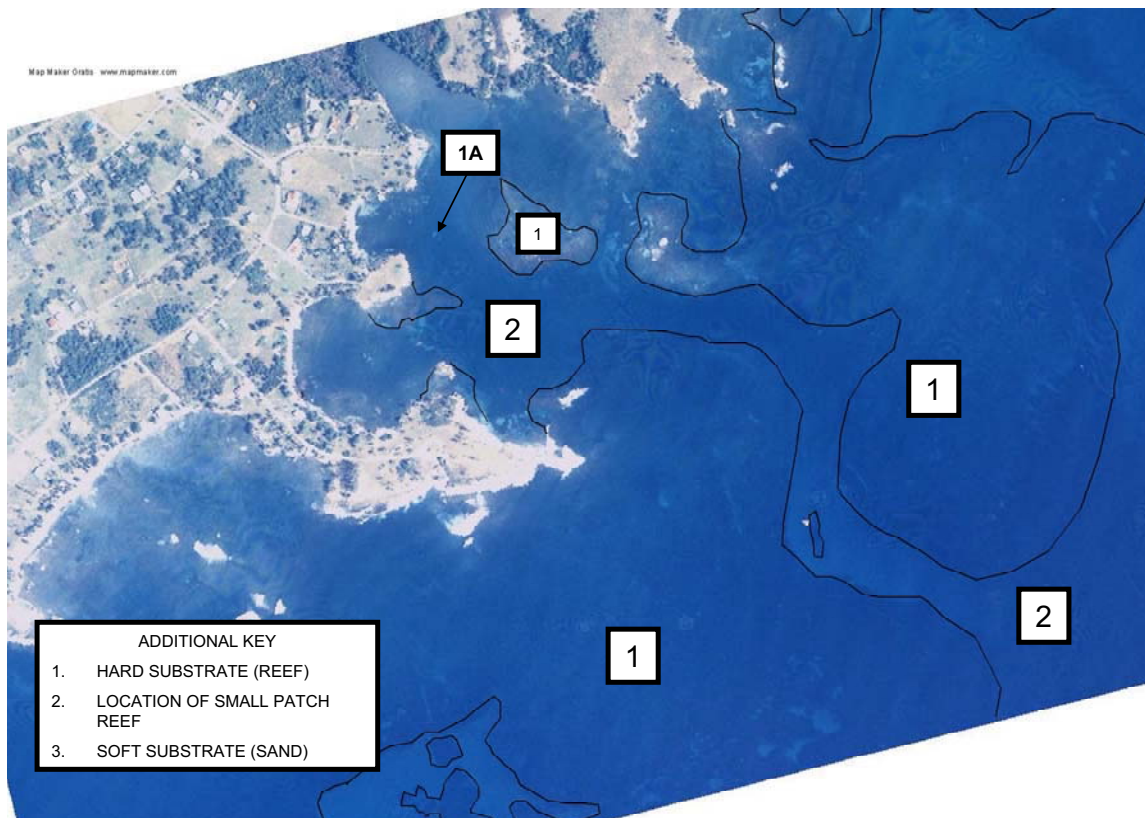

Figure 5-12: Substrates Observed / Interpreted Along Proposed Alignment [Base Image 1991 Aerial Image – Survey Dept.]

The benthic lifeforms present on the hard submerged substrates within the study area were colonized predominantly by turf and macro algae, with scattered corals also being present. The corals observed had diameters between 15 and 45 cm, and were primarily of the Mustard Hill Coral variety (*Porities asteroides*). Plating coral varieties, particularly Lettuce Coral (*Agaricia*

sp.) were also observed, as well as a few examples of large boulder corals, particularly Smooth Starlet Coral (*Siderastrea radians*).

Scattered to dense growths of both Turtle grass (*Thalassia testudinum*) and Manatee Grass (*Syringodium filiforme*.) were observed growing on the sandy substrates within the study area. Turtle grass was observed growing at depths of 1 m to 5 m, while Manatee grass was observed growing in depths of up to 10 m.

Percentage cover relationships between coral and algae benthic lifeforms on hard substrates were in the order of 12% coral cover to 88% algae cover.

The dominant mobile lifeforms observed at the study area were fish, specifically Sergeant Major (*Abudefduf saxatilis*), Dusky Damselfishes (*Stegastes fuscus*), and Bluehead Wrasses (*Thalassoma bifasciatum*).

Numbers of each species observed were low, estimated at less than 10 individuals per 100 cubic meters of water surveyed over the reefs. Overall sizes of the individuals observed were also low, being less than 15 cm in length.

Plates depicting the marine environment are presented in Appendix IV.

Conclusions:

1. The marine study area represents a shallow moderately deep area underlain with a hard carbonate substrate, with a sand channel (approximately 100 meters wide) bisecting the hard substrate.
2. The percentage cover relationships between coral and algae observed on the hard carbonate substrate suggest a coral reef in various stages of stress, due to eutrophication.
3. Two seagrass lifeforms were present within the shallow (<10 m) sections of the sand channel observed within the study area, with Turtle Grass being present on sand in water depths of less than 5 m, and Manatee Grass being present in water depths of less than 10 m.

4. The fish types, numbers and sizes observed within the study area were indicative of an area that may be suffering either from habitat degradation or over fishing, or both.

5.3.2.2 Wildlife Resources

No bird species were observed on the site. In addition, no crab holes were observed at the site.

5.3.2.3 Vegetation Resources

Landing Site - The landing site is located in the vicinity of the community of Prospect (Ocean View Close). The vegetation communities observed, are a remnant of the original vegetation, and only contain a portion of the species usually found in a typical coastal community.

Beach pioneer plants such as *Coccoloba uvifera* (Sea grape), *Sesuvium portulacastrum* (Seaside purslane), and *Thespesia populnea* (Seaside Mahoe) were present. This vegetation type is sparse and merges into the road verge approximately 3 m inland.

Inland, succession in vegetation type was observed with a transition to shrubs and grasses. However, this is interrupted rapidly by the organised residential community. Only one undeveloped lot was found close to the landing site. The majority of the trees at the site consisted of mature tree species, approximately 2 m (6 ft) in height. The shrub layer was not well represented, and large areas under the trees were bare. The shrub layer was consistent with *Panicum maximum* (guinea grass). The dominant plants were the Sea Grape (*Coccoloba uvifera*) and West Indian Almond (*Terminalia catappa*), trees common in coastal locations. The substrate showed variations including sandy and loamy.

There were no endemic, rare, threatened or endangered plant species observed at the site. Additionally, none of the plants have significant cultural or economic value. None of these trees will be removed to construct the manhole, which will be dug at the end of the dead end section of Ocean View Close.

SOCIO-CULTURAL ENVIRONMENTAL

6 Socio-Cultural Environmental

6.1 Introduction

Fibralink Jamaica Limited has a vested interest in the opinions, attitudes and views of the constituents of the communities in which it does business. As mentioned elsewhere in this report, this project is relatively non-intrusive and thus has a very narrow sphere of physical influence on people or communities. This report presents the findings of a socio-economic survey conducted in July-August 2007 among residents within the radius of influence of the project.

6.2 Methodology

While the selection of the areas for interviewing were based on the enumeration districts as defined by Statistical Institute of Jamaica (STATIN), the communities as presented in this report were defined in the field by the interviewer and the respondent. Accordingly it is possible for a number of communities to cross Enumeration Districts (ED) boundaries. Table 6-1 outlines the EDs surveyed within the sphere of influence of proposed landing sites for Bull Bay, St. Andrew and Prospect, St. Thomas.

Table 6-1: Enumeration Districts Surveyed

Enumeration District & Code	Total Households	5 % Sample Value
Bull Bay Landing Site, St. Andrew		
East Rural 082	172	9
East Rural 083	276	1
East Rural 084	200	10
East Rural 087	125	6
East Rural 088	160	8
East Rural 089	89	4
East Rural 090	162	8
East Rural 091	227	11
East Rural 092	156	8
		66
TOTAL	1024	

Enumeration District & Code	Total Households	5 % Sample Value
Prospect Landing Site, St. Thomas		
East 086	161	8
East 087	239	12
East 089	200	10
East 090	106	5
East 091	217	11
East 092	271	14
East 093	171	9
TOTAL	1365	68

A Total of 160 surveys were conducted across both proposed landing sites. The surveys were conducted in 10 EDs in the Bull Bay area and 7 EDs in the Prospect area as outlined by the STATIN, which were in relatively close proximity to the proposed project sites. The survey population was devised based on a 5% sample of the Total Households in the area. Figure 6-1 and Figure 6-2 outline the communities surveyed.

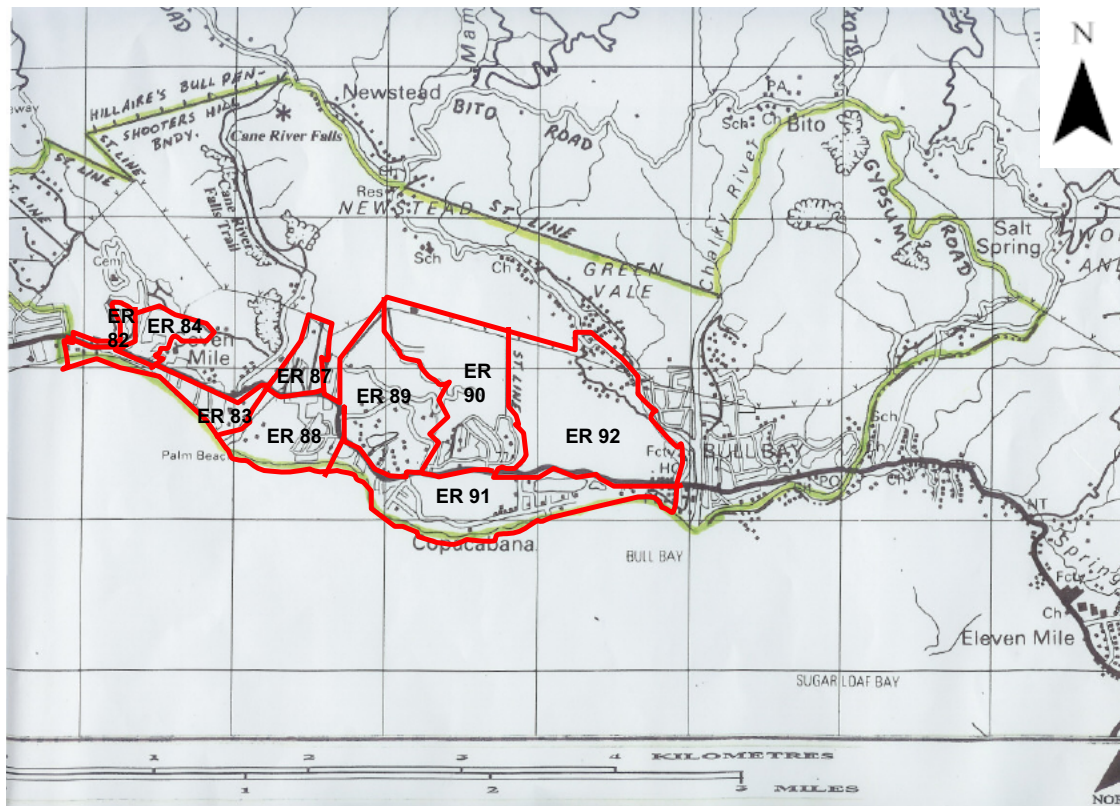

Figure 6-1: Enumeration Districts Surveyed for Bull Bay Landing Site, St. Andrew

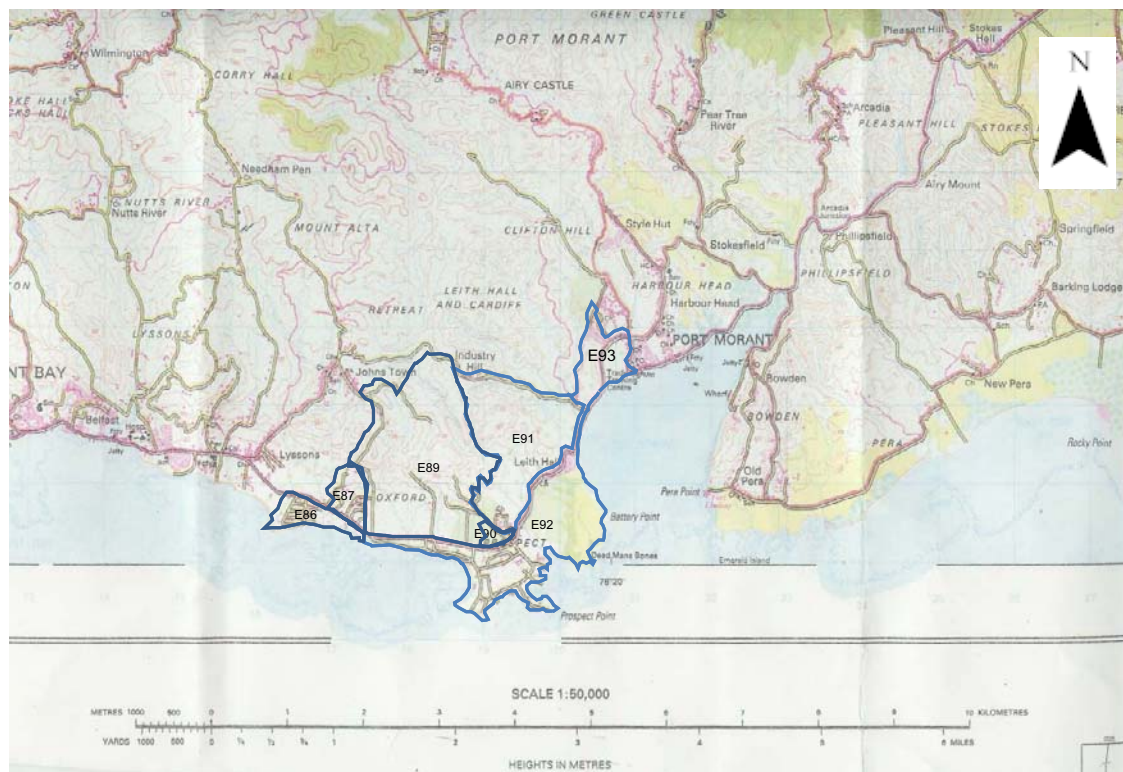

Figure 6-2: Enumeration Districts Surveyed for Prospect Landing Site, St. Andrew

6.3 Survey Findings

6.3.1 Segment 1: Bull Bay Proposed Landing Site

6.3.1.1 Demographic and Social Profile

A total of 68 respondents were covered in this survey, 24 women and 38 men; four surveys showed no response. The majority of the survey population were in the following age groups 22-35 and 36-50 year age group which accounted for 23 respectively. The majority, 43 (65%), of the total survey population have lived in the community for twenty years or more. The total population identified for this area in the 2001 census was 1,024. The information on age and numbers of years lived in the community are presented in the table below.

Table 6-2: Age and Years of Residency within each Community/ED

Community ►	Greenvale Road	Clement	Claymont Road	Palm Beach	Harbour View	Copacobana	Pleasant View	Bayview	Shooters Hill	Ten Miles	Nine Miles	Eight Miles	Seven Miles	Total
Parameter ▼														
AGE														
16-21 years	0	0	0	0	0	1	1	0	0	0	0	1	0	3
22-35 years	0	1	1	0	1	4	6	0	2	3	3	2	0	23
36-50 years	1	0	1	1	2	4	2	0	0	2	1	8	1	23
50+ years	0	0	0	0	2	1	0	5	3	2	3	1	0	17
*NR	0	0	0	0	0	1	0	0	0	0	0	0	0	1
Total	1	1	2	1	5	11	9	5	5	7	7	12	1	67
YEARS OF RESIDENCY														
0-5 years	0	0	0	0	1	0	1	0	0	0	0	1	0	3
6-10 years	0	0	0	0	0	2	2	0	2	0	2	0	0	8
11-20 years	0	0	1	1	2	4	3	0	0	0	0	2	0	13
20+	1	1	1	0	3	4	3	5	3	7	5	9	1	43
*NR	0	0	0	0	0	1	0	0	0	0	0	0	0	1
Total	1	1	2	1	6	11	9	5	5	7	7	12	1	68
*NR – No Response														

6.3.1.2 Awareness of Fibre Optic Cables & its Impact on the Environment

Approximately 80% (54) of respondents did not know what fibre optic cables were, and those that knew seven stated that they are glass cables that transmit information at a faster and cheaper rate.

Sixty-two percent (42) of respondents were aware that the fibre optic cables will bring cheaper, faster and better quality international data transfer, cable TV and high speed internet. Seventy-six percent (52) of respondents believed fibre optic cables would benefit them, of which 28% were of the view they would benefit from receiving information faster and cheaper. The respondents who hold the view that the fibre optic cables will bring lower cost for services comprised 41% of the survey population. The respondents also expressed that fibre optic cables will assist with

easier access to information. The general view on the presence of the fibre optic cables is its ability to attract better services and less expensive.

Of 37 responses, 55% of respondents that answered were of the view that the cable would have no effect on the environment. Less than 19% were unsure, with 11% of the view it would impact air and water quality. Seven percent of respondents were of the view the cables would impact on their health with 21% voicing concerns on the environment and recreation (Figure 6-3). Eighty-four percent (57) of the respondents expressed no problems with this project.

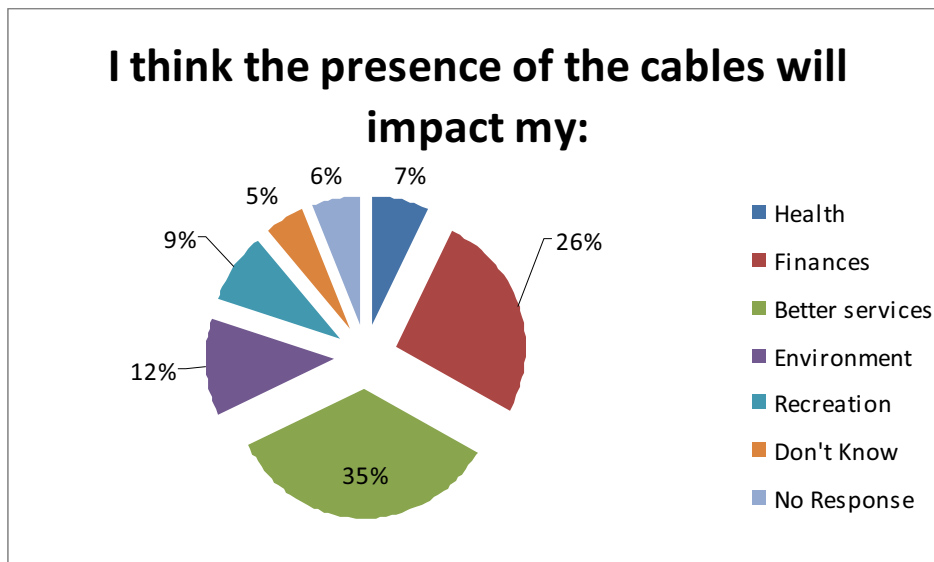

Figure 6-3: Perceived Impact of Fibre Optic Cables

6.3.1.3 Existing & Future Service Amenities

Ninety-seven percent (66) of respondents owned cellular phones while 54% (37) have wired telephones (landline) at home. Thirty-two percent (22) owned computers with 18% of them having internet access at home. At least 84% of respondents have Cable TV and/or DSS systems.

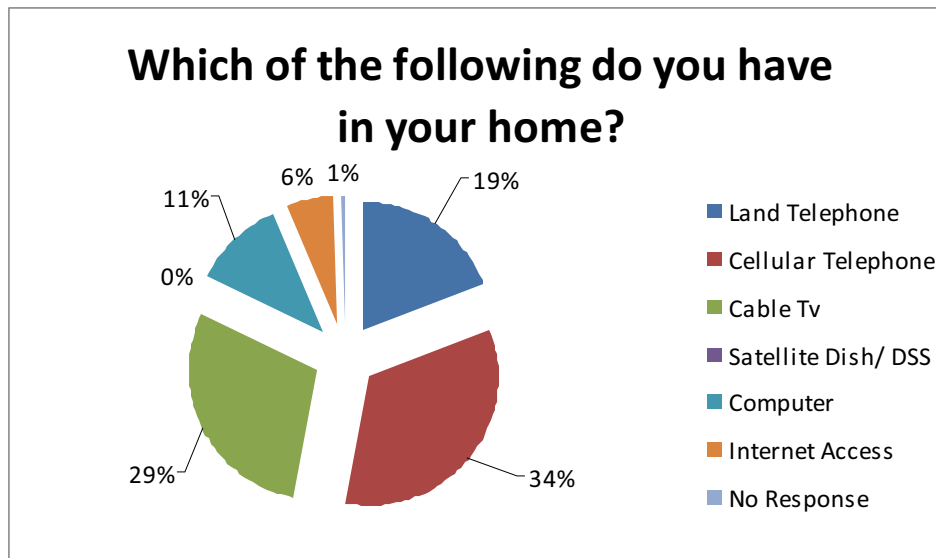

Figure 6-4: Technology in Home

The Internet is significant to most of the respondents interviewed. The internet is primarily used by the respondents primarily at home, work and school. Sixteen percent (16) of persons interviewed had members of their household who did not use the internet at all. Less than 5% of respondents do not know how to use the internet or regard it with little significance. Five percent of respondents are of the view that the cost of accessing the internet is too expensive.

The expectancies of the various communities surveyed are as follows:

- Faster money remittance services (Eg. Western Union, Money Gram) – 50%
- To be able to research information easily – 50%
- More computers in schools – 82%
- More computers in Communities (e.g. Post Offices and Libraries) – 68%
- Computers in more homes – 79%
- Internet Access in more homes – 50%

6.3.2 Segment 2: Prospect Proposed Landing Site

6.3.2.1 Demographic and Social Profile

A total of 73 respondents were covered in this survey, 33 women and 40 men. The majority of the survey population were of the 36-50 years age group. The majority, 35 (~48%), of the total

survey population have lived in the community for twenty years or more. The total population identified for this area in the 2001 census was 1,365. The information on age and numbers of years lived in the community characteristics are presented in the table below (Table 6-3).

Table 6-3: Age and Years of Residency within each Community/ED

Community ►								
Parameter ▼	Oxford Road	Leith Hall	Port Morant	John's Town Road	Lyssons	Retreat	Prospect	Total
AGE								
16-21 years	0	0	0	0	2	0	2	4
22-35 years	1	2	2	0	6	2	10	23
36-50 years	2	4	5	8	6	3	5	33
50+ years	0	1	3	0	2	1	6	13
Total	3	7	10	8	16	6	23	73
YEARS OF RESIDENCY								
0-5 years	0	1	0	0	1	1	6	9
6-10 years	1	0	1	1	3	3	5	14
11-20 years	2	0	0	2	3	2	6	15
20+	0	6	8	5	9	1	6	35
Total	3	7	9	8	16	7	23	73

6.3.2.2 Awareness of Fibre Optic Cables & its Impact on the Environment

Approximately 66% (43) of respondents did not know what fibre optic cables were, and those that knew (34%) stated that they are glass cables that transmit information at a faster and cheaper rate.

Seventy percent (51) of respondents were aware that the fibre optic cables will bring cheaper, faster and better quality international data transfer, cable TV and high speed internet. Eighty-five percent (62) of respondents believed fibre optic cables would benefit them, of which 29% were of the view they would benefit from receiving information faster and cheaper. The respondents who hold the view that the fibre optic cables will bring communication benefits consisted of 10% of the survey population.

The respondents also expressed that fibre optic cables will assist with easier access to information. The general view on the presence of the fibre optic cables is its ability to attract better services and less expensive.

Of 37 responses, 55% of respondents that answered were of the view that the cable would have no effect on the environment (Figure 6-5). Less than 19% were unsure, with 11% of the view it would impact air and water quality. Of 27 responses, 5 respondents were of the view the cables would impact on their health with 4 each with concerns on the environment and recreation. Eighty-seven percent of the respondents expressed no problems with this project.

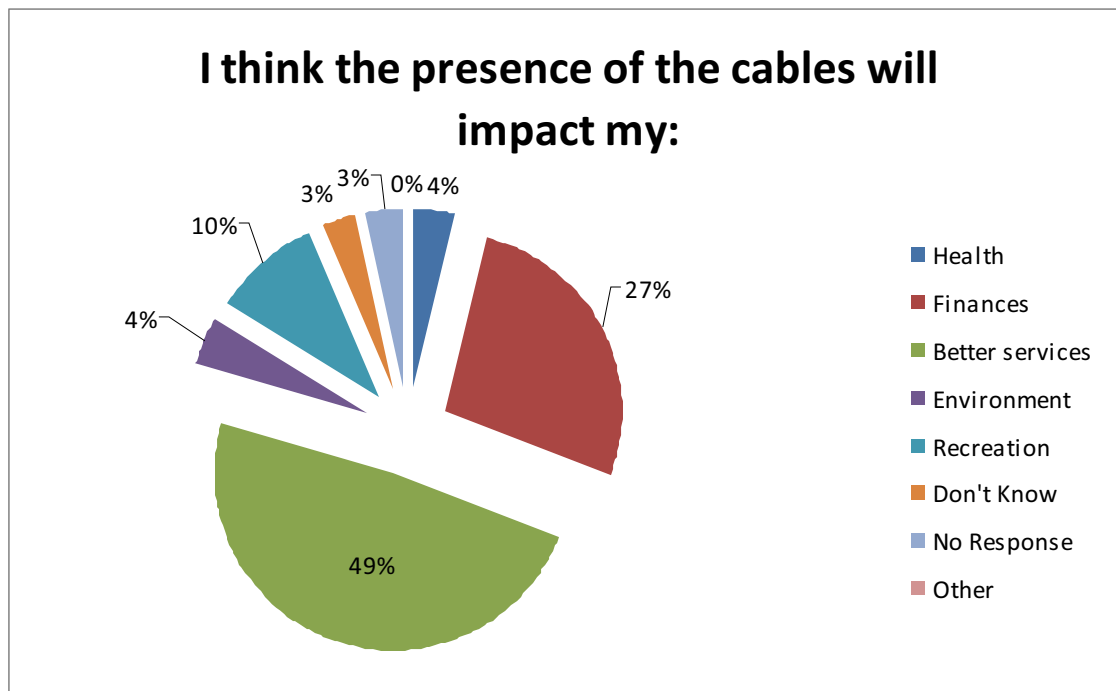

Figure 6-5: Perceived Impact of Fibre Optic Cables

6.3.2.3 Existing & Future Service Amenities

Ninety-five percent (69) of respondents owned cellular phones while 55% (40) have wired telephones (landline) at home (Figure 6-6). Thirty-six percent (26) owned computers with 11% of them having internet access at home. At least 56% of respondents have Cable TV and/or DSS systems.

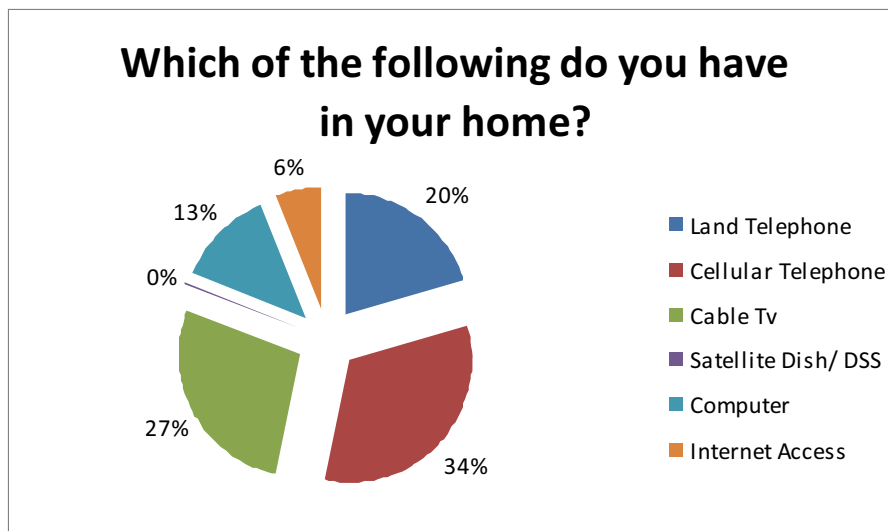

Figure 6-6: Technology in Home

The Internet is significant to most of the respondents interviewed. The internet is used by the respondents primarily at home, work and school. Fourteen percent (15) of persons interviewed had members of their household who did not use the internet at all. Less than 6% of respondents do not know how to use the internet or regard it with little significance. Nine percent (11) of respondents are of the view that the cost of accessing the internet is too expensive.

The expectancies of the various communities surveyed are as follows:

- Faster money remittance services (Eg. Western Union, Money Gram) – 34%
- To be able to research information easily – 49%
- More computers in schools – 86%
- More computers in Communities (e.g. Post Offices and Libraries) – 63%
- Computers in more homes – 60%
- Internet Access in more homes – 48%

6.3.3 Impact on the Marine Community (Fishermen, Bathers etc.)

6.3.3.1 Prospect Region

Most respondents do not depend on the sea to make a living, however, a substantial number of persons; particularly in Port Morant are fish vendors. Port Morant is the fishing beach used the

most by residents followed by Lyssons Beach, Leith Hall and Prospect. Bathing and/or marine recreation accounted for less than 5 percent of respondents answers.

Within this region most fishermen (78%) have not excelled in the education system further than Secondary School and 7% of fishermen do not have any formal schooling. At least 17 fishermen have been working for 20 years or more, most belonging to associations such as Port Morant Fishing Association, St. Thomas Fishing Cooperation and Leith Hall.

Of the 26 respondents that were identified as fishermen, 65% were in business for more than 20 years. Most can be characterised as professional fishermen; less than 2% considered themselves recreational fishermen. The majority of the fishermen were out at sea at least 3 times per week. Earnings are on average less than \$10,000 per week.

Line fishing accounted for at least 40% of all catches with nets 33% predominantly from 28 ft. fishing vessels largely from Leith Hall and Port Morant with representation of 15% and 48% respectively. Anchors and mooring buoys were identified as the systems used with anchors accounting for more than 63%.

When asked how submarine cables would impact there life, the majority (69%) stated that it would either have a positive impact or no impact at all whilst a few (19%) thought the submarine cables would have a negative impact. Twelve percent were unsure of its impact.

Most fishermen have no other income (80%), while farming made up 16% of some, and 4% supplementing their income through crab hunting.

6.3.3.2 Bull Bay Region

At least 56% of respondents do not depend on the sea to make a living; of those that made a living from the sea, the communities of Nine Miles and Seven Miles were most represented. Of 36 positive responses, 30 used the area for fishing. Nine Miles Beach is the fishing beach used the most by respondents followed by Bull Bay Fishing Beach, Palm Beach and Seven Miles Beach. Bathing and/or marine recreation accounted for less than 5 percent of respondents answers.

Of 22 responses, only 11 fishermen have not excelled in the education system further than Secondary School. Of the 22 respondents that were identified as fishermen, 45% were in business for more than 20 years. Most can be characterised as professional fishermen; less than 2% considered themselves recreational fishermen. Approximately 50% of the fishermen were out at sea at least 3 times per week. Earnings are on average less than \$10,000 per week. Fishermen in the area belong to associations such as Kingston Fishing Co-Op and the Fishing Co-Op of the Fisheries Division.

Line fishing accounted for at least 41% of all catches with nets 39% with about 75% fishing from 28 ft. fishing vessels. Anchors and mooring buoys were identified as the systems used with anchors accounting for more than 71%.

When asked how submarine cables would impact their life, the majority (44%) stated that it would either have a positive impact or no impact at all whilst 39% thought the submarine cables would have a negative impact.

Fifty percent of fishermen identified in this region have other sources of income such as: carpentry (28%) and welding (8%) to supplement their income.

6.3.4 Interpretation

The majority of respondents surveyed are open to the installation of the fibre optic cables. They are willing to learn more about the opportunities and effects, and believe that it will generally make a positive impact on them.

Many highlighted that Businesses would be boosted by this new development, as a result of faster transactions internationally and locally. The vast majority of those surveyed were also aware that fibre optic cables can provide audio-video (cable), data (internet), and (audio-voice) landline capabilities. Most have cellular phones and cable TV, and are aware of technological advances in communication.

Better services were the primary impact from the presence of the cables to most respondents who viewed it as a positive through increased savings etc. Health, the environment and recreation were minor impact areas identified. The major concerns expressed were health is a major

concern of respondents as it relates to the impact from the cables. Sixty-five percent of respondents were of the opinion it would not impact the environment negatively.

Of those that rely on the sea for their livelihood by fishing, anchors were the primary technology used on boats with a minority using mooring buoys.

DETERMINATION OF THE POTENTIAL IMPACTS OF THE PROPOSED PROJECT

7 Determination of the Potential Impacts of the Proposed Project

7.1 Introduction

In the process of undertaking this Marine Assessment, several potential impacts of the proposed project have been identified for each phase of the development. Impacts are evaluated in terms of the actual risk of occurrence, the extent (spatial) and duration, and severity. Cumulative effects of potential impacts of this project in conjunction with the impacts of existing activities/operations are also considered.

Appropriate mitigation measures are also recommended for the various potential impacts identified.

In assessing the significance of potential impacts, various measures are used. These include the use of checklists/matrices, expert knowledge and a keen assessment of the project plans and details. Each parameter is evaluated according to the following:

- ✚ Potential impact - any change to the environment, whether adverse or beneficial, wholly or partially resulting from the proposed activities, products or services
- ✚ Activity – phase of development that action takes place in
- ✚ Environmental receptor - sensitive component of the ecosystem that reacts to or is influenced by environmental stressors
- ✚ Magnitude - A measure of how adverse or beneficial an effect may be
- ✚ Duration - the length of time needed to complete an activity
- ✚ Significance - A measure of importance of an effect
- ✚ Mitigation - Measures taken to reduce adverse impacts on the environment

Also presented are impact matrices (identification and mitigation) that summarise the impacts identified and the mitigations proposed for this project.

The following potential impacts are related to the key aspects of the proposed project. There are no adverse unavoidable negative environmental impacts related to the proposed project. The potential environmental impacts identified for the pre-construction, construction and operating phases of the proposed project includes:

Negative

- Minimal suspended solids during cable laying
- Minimal noise and vibration during construction
- Minimal aesthetics and transient change of land and marine use

Positive

- Improved broadband access by connection to other islands
- Potential vast increase in investment revenue and job creation due to improvements in the telecommunications industry from this project.
- No loss of biodiversity
- No loss of archaeological and historical heritage resources
- No loss of aesthetic appeal
- No loss of commercial and recreational fishing needs.

Table 7-1: Potential Sources of Environmental Impacts

No.	Types of likely environmental issues	Construction Phase	Operational Phase
1	Gaseous emissions	x	x
2	Dust	✓	x
3	Odour	x	x
4	Noise	✓	x
5	Night-time operations	x	x
6	Traffic generation	x	x
7	Liquid effluents, discharges, or contaminated runoff	✓	x
8	Generation of waste or by-products	x	x
9	Storage, handling, transport or disposal of hazardous materials or wastes	x	x
10	Risks of accidents which would result in pollution or hazard	x	x
11	Disposal of spoil material	x	x
12	Disruption of water movement or bottom sediments	✓	x
13	Unsightly visual appearance	x	x
14	Ecological impacts (Marine)	✓	x

No.	Types of likely environmental issues	Construction Phase	Operational Phase
Key	Potential to cause concern	✓	
	Unlikely to cause concern	x	

7.2 Potential Impacts [Physical, Biological, Socio-Cultural]

Activity	Environmental receptor	Type of Impact	Potential Impact	Mitigation	Duration	Significance Level	Likelihood
7.2.1 Aesthetics							
Construction	Humans, Flora & Fauna	Negative	Item A1 – The clearance and removal of any vegetation from the landing sites and proposed cable station will result in a visually negative impact and loss of natural resources. The small buildings that will house the equipment will be of low profile and footprint (except for the Bull Bay site which is existing), and fit into the existing surroundings. All activities on the site will be carefully examined to ensure as little impact on the surrounding communities as possible	Proper upkeep and maintenance of the site will be done. Landscaping and building orientation will be utilized where necessary to enhance the visual aesthetics of the areas.	Short Term	Minor Negative	Moderate
7.2.2 Water Quality/Surface Water Hydrology and Groundwater							
Construction & Operation	Humans, Flora and Fauna	Minor negative	Item WQ1 – It might be suggested that the presence of the cables in the water may decrease the water quality; however, they should pose no threat and will not alter the quality of the water. Temporary impacts on water quality may be realized during the cable landing operations. This however, should be short in duration and limited in the amount of sedimentation that it causes. No chemical impacts are anticipated on water quality.	No mitigation necessary.	Short-term	Minor Negative	Low
Construction	Humans, Flora and Fauna	Minor negative	Item WQ2 - Siltation/Sedimentation may occur as a result of excavation of soil for the manhole, trenching for laying the cable, or from directional drilling.	The timely removal of removed and/or stockpiled soils and the use of containment (berms, bunds or containers) to secure soils and avoid siltation, etc. during incidence of rainfall. Proper securing of any stockpiles	Short-term	Minor Negative	Low
7.2.3 Air Quality							
Construction	Humans, Flora and Fauna	Negative	Item AQ1 – It is possible that a small amount of fugitive dust may be produced during manhole construction at the landing site. Trenching along the roadway also has the potential for observable fugitive dust. Otherwise, this project should not result in any negative air quality events as it relates to fugitive dust. Item AQ2 – Limited heavy equipment will be used and only for short periods. Emissions will therefore not be prolonged, and this is confined to the installation period. Operation will not generate any appreciable	Excavated soil and exposed soil surfaces will be sprinkled as necessary and not allowed to dry out enough to become entrained in wind.	Short Term	Minor Negative	Medium
				Heavy equipment will be maintained in proper working condition to produce minimal emissions.	Short Term	Minor Negative	Low

Activity	Environmental receptor	Type of Impact	Potential Impact	Mitigation	Duration	Significance Level	Likelihood
			amounts of emissions. This project should not result in any negative air quality events as it relates to gaseous emissions.				
7.2.4 Noise & Vibration							
Construction	Humans and Fauna	Negative	Item N1 – Various mechanical equipment, vehicles and site activities may generate noise that may exceed acceptable levels. It is not expected that the project will cause a noise nuisance at any point, that is, neither during installation nor operation. Where necessary, work requiring heavy equipment will be scheduled for day-time and will be brief to minimize the potential for disruption of residents and guests. Operation will not produce any noise.	All equipment used will be properly serviced and in good working condition. Any equipment that is deemed to be too noisy will be removed from service for repair or replacement. Personnel should wear ear protection (e.g. ear plugs).	Short Term	Minor Negative	Low
7.2.5 Wildlife & Vegetation Resources							
Construction and Operation	Fauna	Negative	Item WVR1 – The landing sites do not require any land clearance. The manhole to be constructed is not large and is mostly underground. Directional drilling used will not disturb the soil surface nearshore. The cable station to be constructed will not require the removal of any significant amount of vegetation. As such the loss of habitat will not be significant.	Limit the amount of vegetation to be removed to a minimum. Introduce landscaping as necessary to the area.	Short Term	Minor Negative	Low
Construction & Operation	Fauna	Negative	Item WVR2 - It may be assumed that laying of any form of cables on the sea floor would disrupt marine life, however, it is in the best interest of those laying the cables to avoid corals or other structures in order to protect the cable. The cable is to be laid completely flat on the sea floor. In the case of the Prospect, St. Thomas landing site, the cable will be laid through an area of sea grass and is unavoidable. Every effort will be made to minimize the areas of sea grass interrupted and mitigation measures will be implemented.	In areas where sea grass is unavoidable it is proposed that based on the size of the cable the seagrass over time will grow over the cable thereby concealing it. As such no mitigation is proposed.	Short Term	Minor Negative	Low

Activity	Environmental receptor	Type of Impact	Potential Impact	Mitigation	Duration	Significance Level	Likelihood
7.2.6 Employment & Socio-Economic Impacts							
Operation	Humans	Positive	<p>Item E1 – When fully implemented, i.e. the cable has been installed and the infrastructure has been prepared, the project will result in significant job creation across the island. Jobs will be realized through increased telecommunication and other related industries on the island.</p> <p>All the phases of the project implementation will generate local employment (some more than others) but the cumulative impact will be significantly and positive for the Jamaican economy.</p>	Positive impact. NO MITIGATION is REQUIRED	Long Term	Major Positive	Moderate
			<p>Item E2 – Due to the services which can be received via installation of Fibre Optic cables, such as, faster remittance, faster transmission of data (sending and receiving), over broad band internet, better telecommunications, safer and less vulnerable international connections etc., there will be several positive impacts on the entire island. These include:</p> <ul style="list-style-type: none"> ▪ Remittances would be received more quickly, therefore there could be an increase in the remittances sent to the island. This would in turn mean an increase in revenue for the country. ▪ Due to easier access to information (internet), the scope of knowledge of individuals would increase. Also, the less time spent obtaining this information, the more time would be left available for other activities. ▪ Jamaica would become an example in the Caribbean of high quality international telecommunications. Also, in inclement weather, the risk of service disruption would be very low. This ensures that productivity is not disrupted. ▪ Cheaper communication service. With this decrease in cost, the service would be affordable to more people, improving the overall standard of living. 	These are positive impacts, therefore, NO MITIGATION is REQUIRED	Long Term	Major Positive	High

Activity	Environmental receptor	Type of Impact	Potential Impact	Mitigation	Duration	Significance Level	Likelihood
7.2.7 Solid Waste							
Construction	Humans	Negative	Item SW1 – Waste stream in the form of packaging and rubble are potential solid waste. A properly implemented and executed solid waste management plan will remove this negative potential. Fibralink has existing policies to handle this impact.	Solid waste in the form of packaging waste etc. will be removed to an approved landfill facility. Waste rubble not used in the reinstatement of roadways will similarly be disposed of and material from the directional drilling which is innocuous clay material.	Short term	Minor Negative	Low
7.2.8 Occupational Health and Safety							
Construction	Humans	Negative	Item OHS1 – Fibralink is committed to the goal of zero accidents and will employ best practices to achieve worker health and safety compliance.	Adherence to the existing occupational health and safety standards and policies such as dust abatement technologies and the use of eye and hearing protection aids.	Long term	Minor Negative	Low

7.3 Impact Identification and Mitigation Matrices

Table 7-2: Impact Identification Table - Bull Bay, St. Andrew

	Marine Assessment Activities														Cable Station Operation	
	Landing Site Preparation				Cable Installation				Cable Station Construction							
	Site Surveying	Site Clearance	Solid Waste Disposal	Manhole Construction	Cable Laying (marine)	Cable routing (land)	Trenching	Materials Sourcing	Materials Transport	Construction Camp/Materials Storage	Construction Works	Solid Waste Disposal	Sewage Treatment	Increased workforce		Landscaping
TOPOGRAPHY																
GEOLOGY																
VIBRATION																
RAINFALL																
GASEOUS EMISSIONS/ ODOUR																
AMBIENT NOISE																
DUST																
DRAINAGE																
TEMPERATURE																
NATURAL HAZARD VULNERABILITY																
Water Quality																
SEDIMENTATION																
CHEMICAL IMPACT																
Ecological Parameters:-																
TERRESTRIAL ECOSYSTEMS																
VEGETATION																
BIRDS																
OTHER FAUNA																
AQUATIC ECOSYSTEMS																
VEGETATION																
FAUNA																
SENSITIVE HABITATS																
Socio-Economic Parameters:-																
AESTHETICS																
LAND USE COMPATIBILITY																
EMPLOYMENT																
FOREIGN EXCHANGE EARNINGS																
STRUCTURES/ROADS																
WASTE MANAGEMENT																
TRAFFIC ON THE ACCESS ROAD																
INCREASED CRIME																
HAZARD VULNERABILITY																
SOLID WASTE DISPOSAL																
SEWAGE DISPOSAL																
FISHING INDUSTRY																
Occupational Health & Safety																

KEY

	Major Negative
	Minor Negative
	No Impact
	Major Positive
	Minor Positive

Table 7-3: Impact Identification Table - Prospect, St. Thomas

	Marine Assessment Activities															
	Landing Site Preparation				Cable Installation				Cable Station Construction							
	Site Surveying	Site Clearance	Solid Waste Disposal	Manhole Construction	Cable Laying (marine)	Cable routing (land)	Trenching	Materials Sourcing	Materials Transport	Construction Camp/Materials Storage	Construction Works	Solid Waste Disposal	Sewage Treatment	Increased workforce	Landscaping	Cable Station Operation
																
TOPOGRAPHY																
GEOLOGY																
VIBRATION																
RAINFALL																
GASEOUS EMISSIONS/ ODOUR																
AMBIENT NOISE																
DUST																
DRAINAGE																
TEMPERATURE																
NATURAL HAZARD VULNERABILITY																
Water Quality																
SEDIMENTATION																
CHEMICAL IMPACT																
Ecological Parameters:-																
TERRESTRIAL ECOSYSTEMS																
VEGETATION																
BIRDS																
OTHER FAUNA																
AQUATIC ECOSYSTEMS																
VEGETATION																
FAUNA																
SENSITIVE HABITATS																

	Marine Assessment Activities															
	Landing Site Preparation				Cable Installation				Cable Station Construction							
	Site Surveying	Site Clearance	Solid Waste Disposal	Manhole Construction	Cable Laying (marine)	Cable routing (land)	Trenching	Materials Sourcing	Materials Transport	Construction Camp/Materials Storage	Construction Works	Solid Waste Disposal	Sewage Treatment	Increased workforce	Landscaping	Cable Station Operation
Socio-Economic Parameters:-																
AESTHETICS																
LAND USE COMPATIBILITY																
EMPLOYMENT																
FOREIGN EXCHANGE EARNINGS																
STRUCTURES/ROADS																
WASTE MANAGEMENT																
INCREASED CRIME																
HAZARD VULNERABILITY																
SOLID WASTE DISPOSAL																
SEWAGE DISPOSAL																
FISHING INDUSTRY																
OCCUPATIONAL HEALTH & SAFETY																

Table 7-4: Impact Mitigation Table – Prospect & Bull Bay

	Proposed Mitigative Measures							
	Operation & Maintenance Plan	Detailed Bathymetric Surveys	Effective Site Management	Scheduling of Construction Activities	Waste Management Plan	Road Paving and Surfacing	Dust Management Techniques	Installation of Sediment Traps
CLEARING OF SITE VEGETATION								
LEVELLING OF SITE								
TRANSPORTATION OF CONSTRUCTION MATERIAL								
INCREASE IN NOISE								

	Proposed Mitigative Measures							
	Operation & Maintenance Plan	Detailed Bathymetric Surveys	Effective Site Management	Scheduling of Construction Activities	Waste Management Plan	Road Paving and Surfacing	Dust Management Techniques	Installation of Sediment Traps
								
INCREASE IN DUST			Minor Positive	Minor Positive		Minor Positive	Minor Positive	
DISTURBANCE OF FLORA AND FAUNA			Minor Positive	Minor Positive				Minor Positive
AESTHETICS			Minor Positive	Minor Positive	Minor Positive		Minor Positive	
INCREASED EMPLOYMENT								
INCREASED SEDIMENTATION OF COASTAL WATERS			Minor Positive				Minor Positive	
CHANGE IN THE NATURAL DRAINAGE PATTERNS	Minor Positive	Minor Positive	Minor Positive					
SOLID WASTE GENERATION			Minor Positive		Minor Positive			
INCREASED EARNING POTENTIAL FOR COMMUNITY								
TRAFFIC INCONVENIENCES			Minor Positive	Minor Positive		Minor Positive		

Key	
No Impact	
Minor Negative	Minor Positive
Major Negative	Major Positive
Minor Positive	Minor Positive
Major Positive	Major Positive

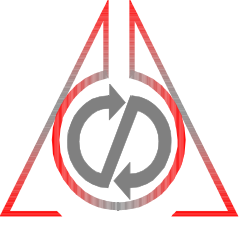
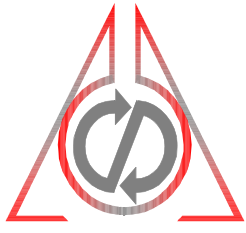
ENVIRONMENTAL MANAGEMENT AND MONITORING PLAN

8 Environmental Management and Monitoring Plan

8.1 Introduction

Any scale of operation that is being started without any existing infrastructure is generally divided into three phases:

1. Pre-construction phase
2. Construction phase
3. Operational Phase.

All phases require independent monitoring regimes in order to ensure that the integrity of the environment is preserved.

The type of development being proposed in this Marine Assessment is estimated to have minimal impact on the environment in all phases. In fact, the only phases which really require monitoring are the pre-construction phase and the construction phase. The operational phase is automated and does not involve any extensive operations that require human intervention or the use of chemicals, physical tools, etc. The operation is also a zero discharge operation and does not require any frequent input of raw materials other than electricity for sustained operations.

All data recorded, all observations made, and all analytical techniques employed will be documented, summarized, compiled and submitted to NEPA according to the accepted terms outlined for each phase of this development, and according to any additional terms outlined in the permit license, if granted.

8.2 Pre-Construction Phase

This phase involves the preparation of the proposed sites for the facilitation of the development. Site preparation will occur on the on-shore areas.

For the preparation of the onshore sites, the following measures are proposed:

- During site clearing activities, any animals or plants that are in the area designated for the cable buildings must be evaluated to ensure that no endemic, rare or protected species will be affected. Any such species identified will be documented and the proper authorities

notified so that the best relocation practice can be employed or if necessary the location of the building changed to accommodate the species.

- Where identified, endemic and rare species should be preserved in place or collected for transplanting (As Observed)
- Stockpiles of soil and vegetative debris generated during site clearing activities should be monitored and maintained to eliminate generation of fugitive dust. (Daily Monitoring)
- Noise levels along the perimeters of the project area should be monitored and recorded to insure that activities at the site are not exceeding standards. (Daily Monitoring)

8.3 Construction Phase

Construction is slated to occur on both near-shore and onshore areas. Directional drilling will be employed to bring the cable in from the sea to the nearshore manhole that will be constructed onshore. Such an activity will warrant the monitoring of turbidity levels of the near shore areas for the duration of the construction phase. The turbidity levels will provide insight on the magnitude of the occurrence of processes such as siltation and sedimentation, which may be caused by the drilling and the on shore construction activities.

Construction at each landing site is estimated to be a one day affair. During the construction process on the onshore areas the following areas will be monitored:

- Solid Waste Management - Ensure that solid waste management plan is prepared, and that workers are aware that no solid waste material should be scattered around the site. Monitor availability and location of skips/dumpsters.
- Exposed soil areas must be monitored to determine potential for erosion, silting and sedimentation particularly during storm events. Reinstatement of cuts along roadways must be done in the shortest possible timeframe. Signs must be erected to highlight areas where work is being done. (Weekly Monitoring)
- If erosion, silting or sedimentation is a potential or occurs, immediate steps must be taken to negate the impact on the coastal waters and other receptors where applicable. (As Needed)
- If any cultural heritage resources are unearthed during construction activities, activities should be stopped and the Jamaica National Heritage Trust contacted. (As Needed)

- Noise levels along the perimeters of the project area should be monitored and recorded to insure that activities at the site are not exceeding standards. (Daily Monitoring)

APPENDIX

APPENDIX I

Appendix I: Approved Marine Assessment Scope of Detail

Marine Assessment Scope of Detail

Conrad Douglas & Associates Limited (CD&A) has been contracted to conduct the Marine Assessment for the implementation of the proposed Fibre Optic Cable Landing Sites in Jamaica. In keeping with the requirements of the National Environment and Planning Agency (NEPA), CD&A provides this Draft Scope of Detail document for the captioned project.

Background

Columbus Communications Jamaica Limited through its Jamaican affiliate Fibralink Jamaica Limited is undertaking the construction and operation of a redundant sub-marine fibre optic cable system in Jamaica to maintain network diversity and reliability. The sub sea fibre cable will connect Boca Raton, Florida with Jamaica and Columbia. This will facilitate continued high quality connectivity and broadband access for Jamaica through another international port to North and South America. This will greatly improve the reliability of the telecommunications industry in Jamaica.

The landing party in Jamaica will be Columbus Networks affiliate and license holder in Jamaica, FibraLink Jamaica Limited.

FibraLink has been awarded a licence to install and operate the fibre optic system by the Office of Utilities Regulation in Jamaica. The proposed landing sites in Jamaica are as follows:

1. New Little Copa Club, Bull Bay, St. Thomas
2. Ocean View Close, Prospect, St. Thomas

This project will present the country with another option for linking with the outside world and provide a level of redundancy to the network to safeguard against total disruption of services in the event of significant natural disasters, representing great economic and social potential. It will serve to drive the cost of e-services down, creating a more affordable environment for commercial and personal broadband communication availability in the island.

Study Area

The study area will include to some extent Jamaica's territorial waters and two (2) landing sites, namely in the Bull Bay (St. Andrew) and Prospect (St. Thomas) areas. The projected sphere of influence of the study sites is expected to be no more than 2km in radius of identified sites. The Bull Bay site is approximately 1.5 km east of the existing Fibralink fibre optic landing site.

Scope of Work

The Scope of Work requires that a Marine Assessment be carried out. The Scope of Work is listed under the tasks to be undertaken below.

Tasks to be Undertaken

The tasks to be undertaken are structured to meet the requirement of the National Environment and Planning Agency (NEPA), Ministry of Health (Environmental Health Unit), Office of Disaster Preparedness and Emergency Management (ODPEM) and all other relevant governmental and regulatory agencies.

Task 1: Project Description

CD&A will identify all the critical activities, equipment and procedures that will be implemented throughout the major stages of the project. The project designs, specifications, and schedules will be clearly presented in this section. The completed project description will include at a minimum, details such as:

- Description of the materials of construction and structure of the fibre optic cable. Method of linkages and securing along its alignment as well as linkages from sea to land
- Project implementation schedule, descriptions of preconstruction, construction and occupational activities
- Detailed description of project components, with special emphasis on those that may cause potential environmental impacts during each phase.
- Review of designs with details to show how FibraLink will be able to maintain environmental compliance and not negatively impact the environment. This includes structural, operational and emergency safeguards
- Mode of operation, hours of operation and types of machinery and equipment to be used. Special emphasis will be placed on activities that involve the generation of waste materials
- The number of employees proposed for the operation
- Description of the role of regulatory agencies, NEPA, Parish Council, Marine Police and others in terms of inspections and follow-up visits

The relevance of the project to national development will also be evaluated.

Task 2: Policy, Legislative and Regulatory Framework

All International and Government of Jamaica policies, legislation and regulations relevant to the project will be identified and analysed. This will be a comprehensive analysis from which FibraLink will be advised as necessary to ensure that all phases of the project maintain compliance.

Task 3: Analyses of Alternatives

Alternative landing sites and plans (inclusive of the preferred and no action alternatives) will be evaluated in terms of the economic, logistical, and environmental selection criteria, inclusive of their potential for positive and negative impacts, and the degree to which the negative impacts may be mitigated. In the case of each alternative reviewed a rationale will be provided for selection or non-selection.

Task 3.1: Description of Current and Proposed Broadband Systems in Jamaica

CD&A will utilize both graphical and descriptive approaches to describe and compare the existing fibre optic equipment and capabilities on the island against those of the proposed

upgrade, to highlight effectively the benefits both environmentally and economically of the proposed project. This will include at a minimum:

- Characteristics of the methods, equipment and processes
- Designs, size, scale and capacity
- Equipment and machinery

Task 4: Description of Current Environmental Baseline Data

This task seeks to identify the principal parameters of the natural and human environment which may be sensitive to the project, and to compile, analyse, assess and document the present (baseline) status of this environment. This database will provide an invaluable baseline against which future impacts on the environment may be measured. The environmental setting and baseline parameters will address primarily the bio-physical environment and the socio-cultural environment.

The Bio-Physical Environment

- Topography, basic land, and marine conditions.
- geomorphology and earth surface processes
- natural hazard vulnerability and risk
- marine environment (territorial waters)
- rainfall characteristics
- wind speed and direction
- background noise levels
- water quality surveys
- floral and faunal types and their distribution
- the ecology of the area (identification of any rare, endangered and threatened species, and habitats)

These studies will incorporate the two (2) proposed landing sites and the surrounding environment/communities that may be impacted. A potential environmental sphere of influence will be developed based on the information collected and the potential for impact.

The Socio-Cultural Environment

Both primary and secondary data sources will be developed involving: documentation of the existing human environment will include a review and analysis of census data. Populations in the environs of the landing sites will be taken into account in compiling the socio-economic baseline information. A coded, pre-tested socio-economic survey instrument will be developed and administered in the communities located within the anticipated sphere of influence of the project. The findings will be presented in a manner to categorize and identify socio-economic impacts (perceived and real) in terms of positive and negative.

Among the key elements which will be addressed are:

- the spatial distribution of coastal communities within the sphere of influence of the proposed project
- demographic profile

- use/dependence on natural resources
- knowledge of the proposed project and their disposition towards it
- occupations and skills
- employment levels
- economic activity
- relevant historical heritage in the vicinity of the site

Task 5: Impact Identification

All potential impacts on the receptors and attributes of the environment, both adverse and beneficial, will be identified and their duration, magnitude, reversibility, and extent described and quantified. In addition, in the case of positive impacts, recommendations will be made on their maximisation. This will cover all phases of the project. This will include qualitative as well as quantitative assessments. Areas to be addressed will include at a minimum:

- Human population of the area
- Flora and fauna
- Marine environment
- Weather and climate
- Cultural Heritage Resources

Cumulative impacts will also be addressed by taking into account existing operations in the area, particularly in respect of their contribution to the baseline and the incremental changes which will be caused by the proposed works, if any.

Task 6: Impact Mitigation

An impact mitigation plan will be developed. This will include the measures to be implemented in the environmental action plan for each potentially negative impact identified. These will also include mitigative measures to be applied during all phases of construction and operation to minimise or eliminate any identified negative impacts. Estimated costs to implement the mitigation items in the plan will be presented. Additionally a Disaster Preparedness Plan for the project will be developed based on findings of the Natural Hazard and Vulnerability section of the report.

Task 7: Environmental Management and Training

CD&A will work to develop management and training protocols to govern the actions of employees and contractors within Jamaica's territorial waters and on land during all phases of the project. The protocols developed will address all the steps which will be taken during the site preparation, construction and operating phases of the project to avoid, or mitigate potential impacts, as well to maximise beneficial impacts. Where necessary, required training activities will be defined and in conjunction with FibraLink these will be developed and tested. This is an important step in the project as it speaks to issues of regulatory compliance, liability, and occupational health and safety.

Task 8: Environmental Monitoring Plan

CD&A will develop an environmental monitoring plan in which all the parameters to be monitored and the methods to be used will be identified and described. This plan will include at a minimum:

- An organizational/responsibility chart
- Institutional arrangements for carrying out the work
- Parameters to be monitored
- Methods to be employed
- Standards, guidelines or protocols to be used
- Evaluation of results
- Schedule and duration of monitoring
- Initiation of mitigative actions
- Format and frequency of reporting

Task 9: Risk Assessment/Natural Hazard Vulnerability

All potential physical risks associated with the proposed project, such as hurricanes, earthquakes, fires, explosions, spillages, flood events and landslides will be identified and addressed. Methods to address these will also be documented.

A Disaster Preparedness Plan/Emergency Response Plan for the construction sites will be developed based on the findings of this task and through consultation with the Office of Disaster Preparedness and Emergency Management (ODPEM).

Task 10: Public Participation

CD&A will follow international and national guidelines for public participation that the public, particularly those who may be impacted (negatively or positively) by the project. This will begin as an early stage in planning and project implementation. Public participation will provide early indications of public perception and potential areas where problems may arise and what it may take to handle those situations. While the socio-economic survey will introduce the project to the community through a fact sheet, informal meetings and collaborations will be held with community leaders and members to explain the project.

CD&A recommends the following procedures and schedule for meeting with communities in the estimated radius of influence of the facility:

Procedures:

- Identify and classify the various communities in the radius of influence
- Identify and involve “community leaders” early in the process
- Listen carefully and record the ideas, needs, and wants of the communities (where possible implement their input into the process)

CD&A recommends that this type of interface with the community continue as long as the project is being implemented and beyond if practicable, to foster good community relations.

The Marine Assessment Report

CD&A will present all findings in the Marine Assessment, reflecting the headings in the body of the approved Scope of Detail, as well as other references. Eight (8) hard copies and one electronic copy of the report will be submitted to NEPA. It will include an appendix with items such as maps, site plans, the study team, photographs and other relevant information.

The Marine Assessment Report will take the following form:

- Executive Summary
- Project Description
- Policy, Legislative and Regulatory Framework
- Analyses of Alternatives
- Description of Current Physical, Environmental and Socio-Economic Baseline Data
- Risk Assessment/Natural Hazard Vulnerability
- Impact Identification
- Impact Mitigation
- Environmental Monitoring Plan
- Environmental Management and Training
- List of References
- Appendices

APPENDIX II

Appendix II: Fibralink Licence & Signature Page Scan



MINISTRY OF COMMERCE, SCIENCE AND TECHNOLOGY (with ENERGY)

PCJ Building, 36 Trafalgar Road, Kingston 10, Jamaica, W.I.
Tel: (876) 929-8990-9 Fax: (876) 960-1623
E-mail: admin@mct.gov.jm Website: <http://www.mct.gov.jm>

December 20, 2004

The Managing Director
Fibralink Jamaica Ltd.
24-26 Grenada Crescent
Kingston

Dear Sir/Madam,

I am pleased to inform you that you have been granted a license for the construction and operation of a Submarine Fiber Optic Cable Network.

Enclosed is the signed license.

Yours truly,

Phillip Paulwell
MINISTER

Encl.

PORTFOLIO AGENCIES AND DEPARTMENTS: Anti-Dumping and Subsidies Commission, Bureau of Standards, Central Information Technology Office, Consumer Affairs Commission, Electricity Division, Fair Trading Commission, Food Storage and Prevention of Infestation Division, Jamaica Intellectual Property Office, Petrojam Limited, Petrojam Ethanol Limited, Petroleum Company of Jamaica, Petroleum Corporation of Jamaica, Post and Telecommunications Department, Registrar of Cooperatives and Friendly Societies, Office of the Registrar of Companies, Rural Electrification Programme, Scientific Research Council, Spectrum Management Authority, Trade Board Limited

such renumbering of those Parts or sections in the Act, as a result of amendment or repeal of that Act.

DATED this 20th day of December 2004

.....
MINISTER OF COMMERCE, SCIENCE AND TECHNOLOGY

APPENDIX III

Appendix III: Project Team

Information and data for this Marine Assessment was compiled from work done by the following persons and/or organisations:

Dr. Conrad Douglas
Mr. Orville Grey
Mr. Wayne Morris
Mr. Marco Campbell
Ms. Stephanie McIntyre
Geomatrix
Mr. Peter Wilson-Kelly – Marine Specialist

APPENDIX IV

Appendix IV: Marine Photo-Inventory

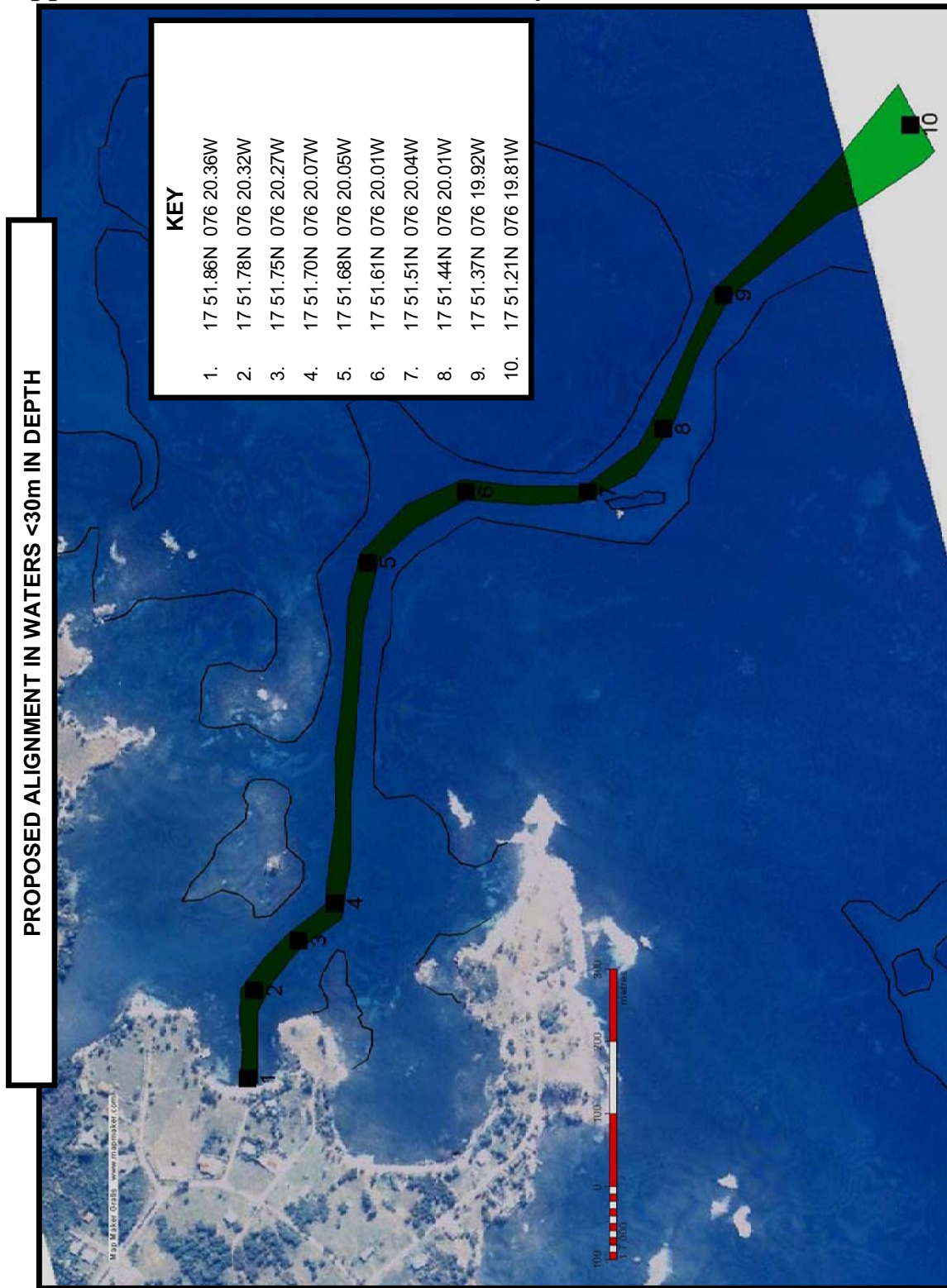

Plate 8-1: Proposed Alignment in Waters <30m in Depth

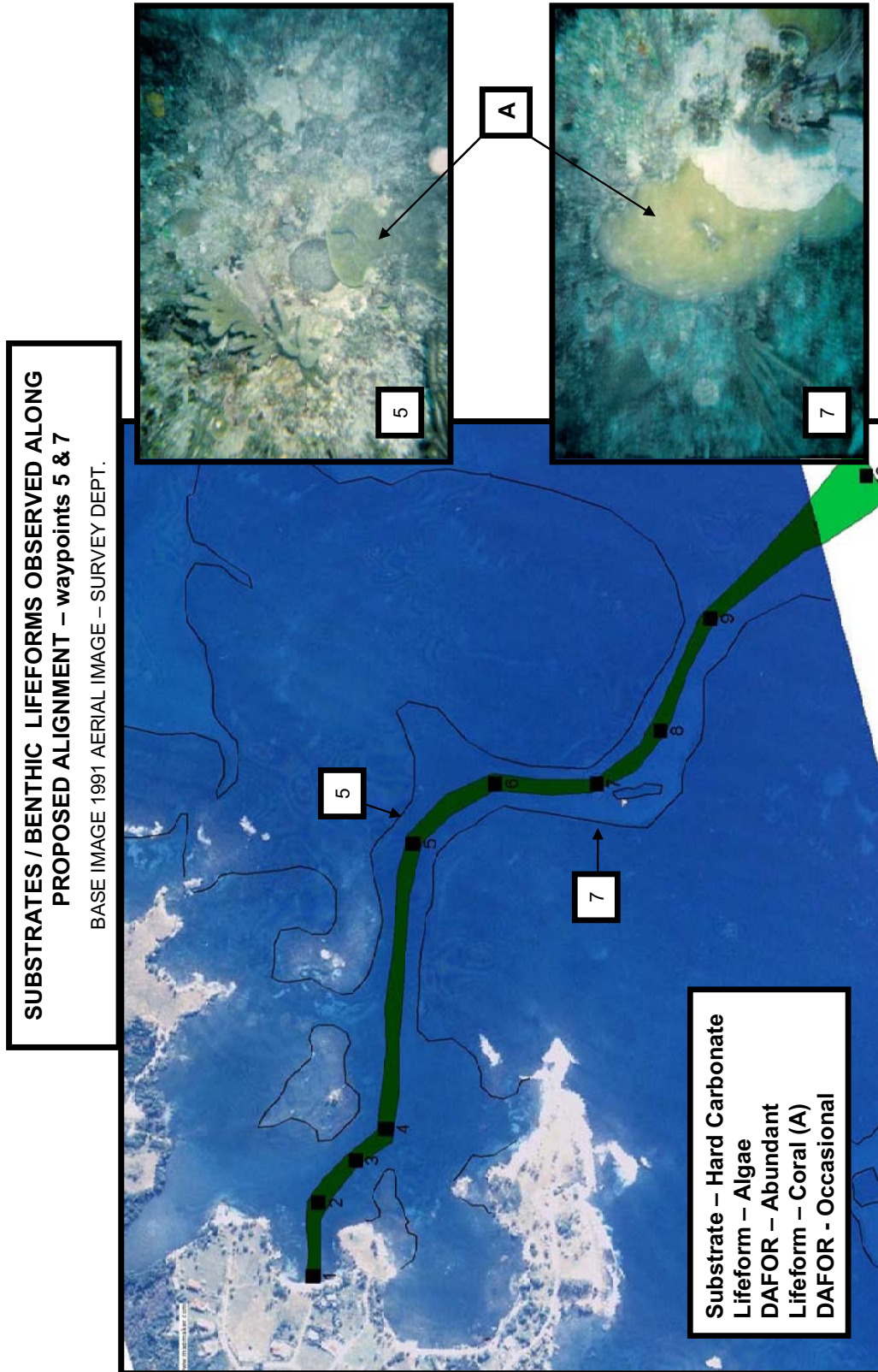

Plate 8-2: Substrate / Benthic Lifeforms Observed Along Proposed Alignment at Prospect, St. Thomas - Waypoints 5 & 7

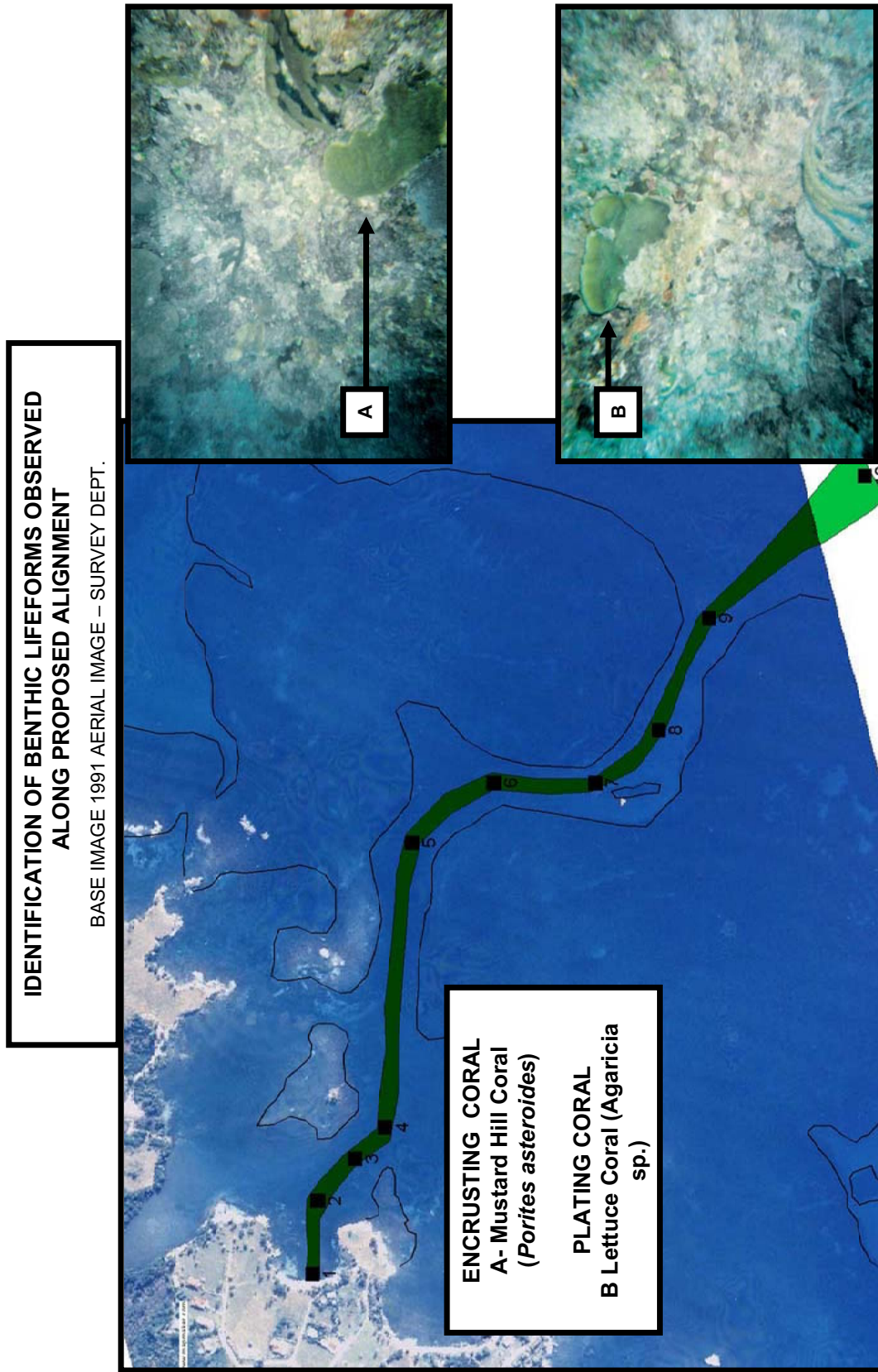

Plate 8-3: Identification of Benthic Lifeforms Observed along Proposed Alignment – Encrusting and Plating Corals

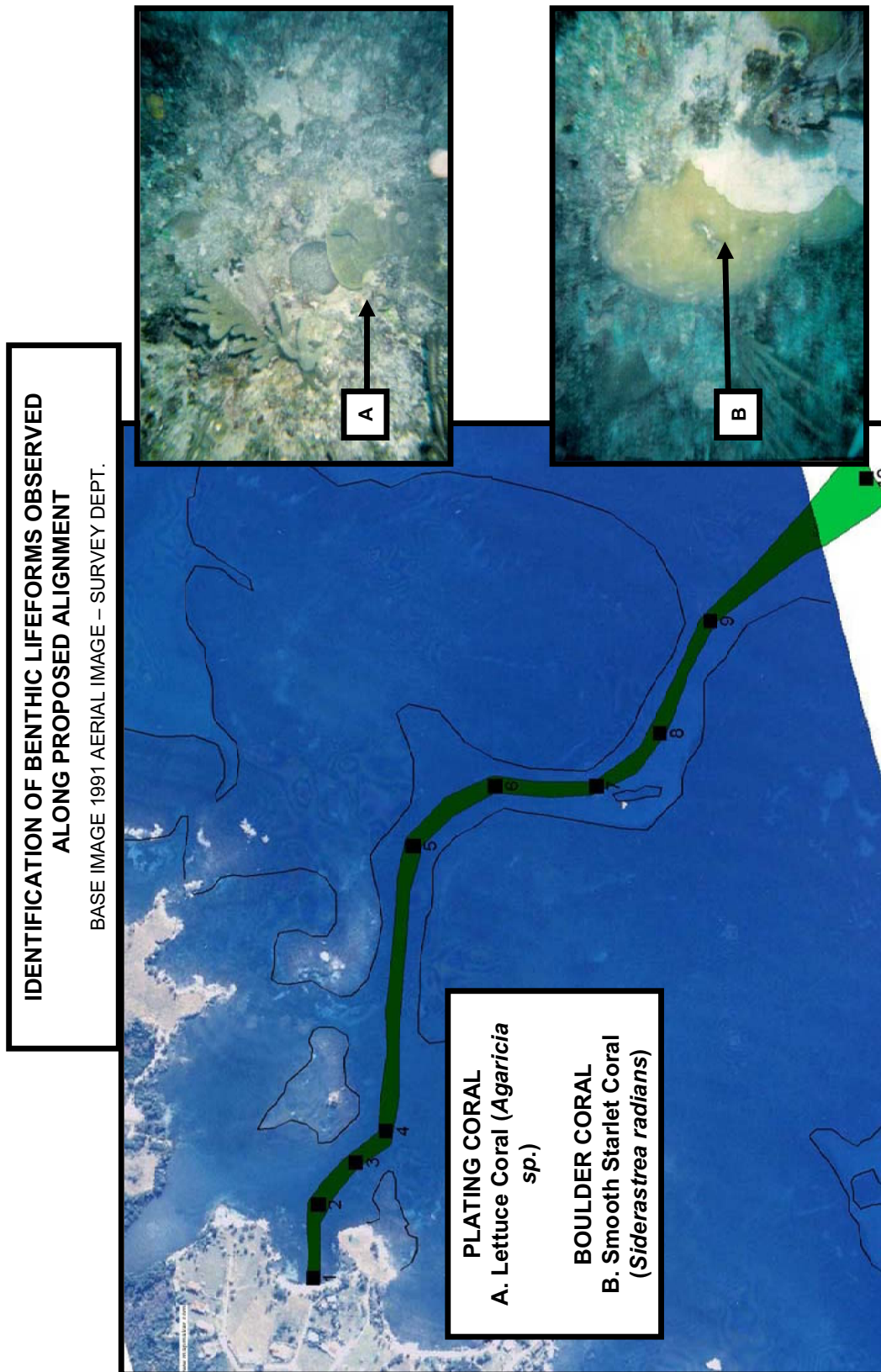

Plate 8-4: Identification of Benthic Lifeforms Observed along Proposed Alignment – Plating and Boulder Corals

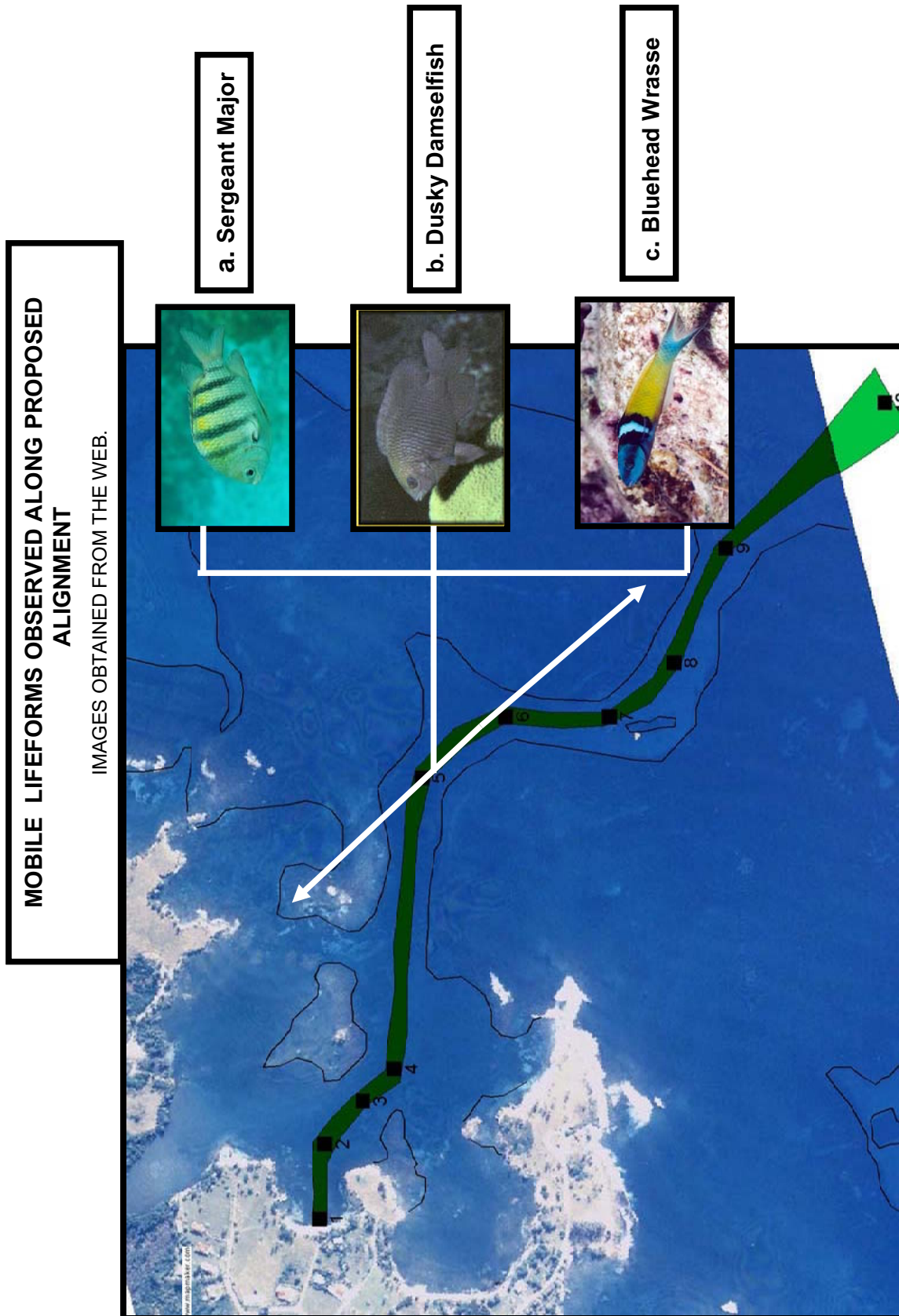

Plate 8-5: Mobile Lifeform Observed along Proposed Alignment

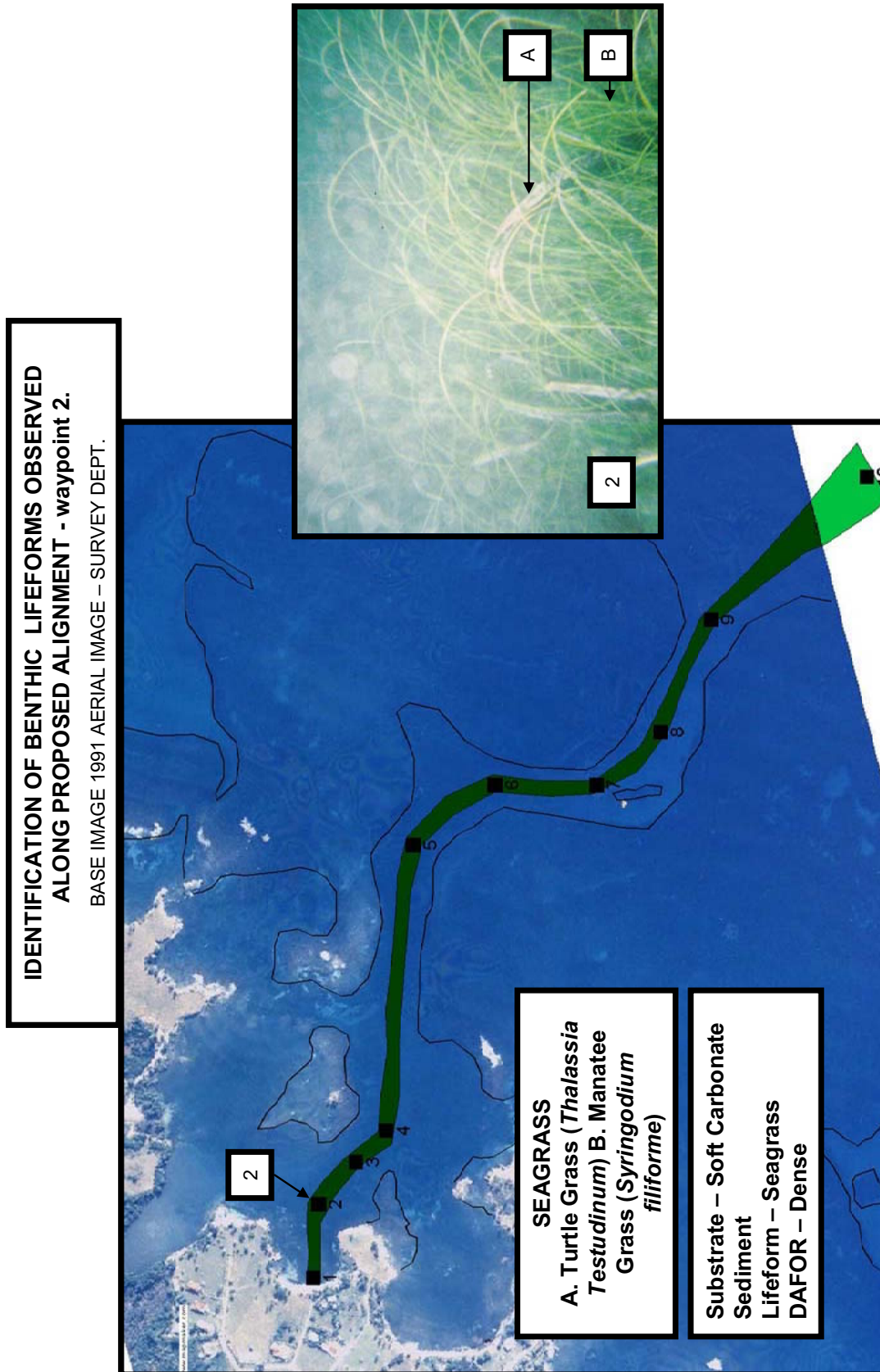

Plate 8-6: Identification of Benthic Lifeforms Observed along the Proposed Alignment - Waypoint 2

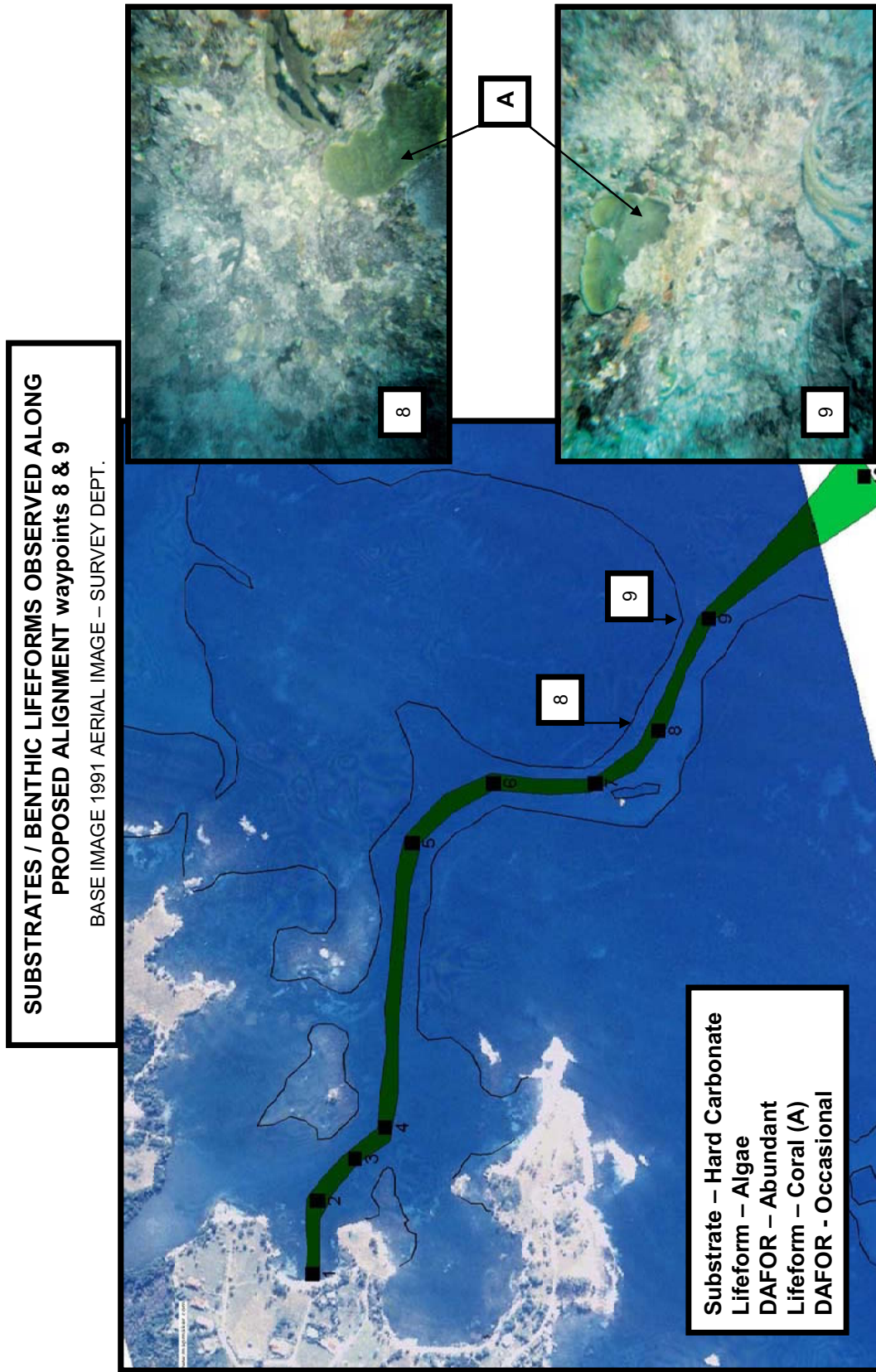

Plate 8-7: Identification of Benthic Lifeforms Observed along the Proposed Alignment - Waypoint 8 & 9