

Prepared by:



**Environmental
Technology Limited**

Science &

14 Carvalho Drive
Kingston 10
Jamaica W.I
Tel: (876)929-8824
(876)929-0023
(876)929-0025
Fax: (876)929-8823

SECOND ADDENDUM TO THE ENVIRONMENTAL IMPACT ASSESSMENT



FOR
GRAND PALLADIUM
LADY HAMILTON
RESORT & SPA
AT POINT, HANOVER

Table of Contents

TABLE OF CONTENTS	I
<i>LIST OF FIGURES</i>	I
COMMENTS RE FIESTA EIA	1
1 DRAINAGE	1
1.1 COMMENTS	1
1.2 RESPONSE	2
2 NUTRIENT CONTAMINATION	6
2.1 COMMENT	6
2.2 RESPONSE	6
2.3 COMMENT	6
2.4 RESPONSE	6
2.5 COMMENT	7
2.6 RESPONSE	7
3 BEACH MODIFICATION	7
3.1 COMMENT	7
3.2 RESPONSE:	7
4 BEACH USE AND PRESCRIPTIVE RIGHTS	8
4.1 COMMENT	8
4.2 RESPONSE	8
5 SHORELINE PROCESSES AND STORM WAVE IMPACTS	9
5.1 COMMENT	9
5.2 RESPONSE	9
6 MARINE WILDLIFE INTERACTIONS	12
6.1 COMMENT	12
6.2 RESPONSE:	12
7 TERRESTRIAL WILDLIFE INTERACTIONS	16
7.1 RESPONSE	16
8 SOCIO-ECONOMIC SURVEY RESULTS	16
8.1 COMMENT	16
8.2 RESPONSE	16

List of Figures

FIGURE 1: PROPOSED GENERAL DRAINAGE LAYOUT AT PROPERTY	4
FIGURE 2: PROPOSED DRAINAGE DETAIL	5
FIGURE 3: 10, 25, 50 AND 100 YEAR RETURN PERIOD FOR WAVE HEIGHTS AT MONTEGO BAY	10
FIGURE 4: 10, 25, 50 AND 100 YEAR RETURN PERIOD FOR SURGE HEIGHTS AT MONTEGO BAY	11
FIGURE 5: BEACH LOCATION AND NUMBER FOR FIESTA HOTEL AT POINT, HANOVER	15

COMMENTS RE FIESTA EIA

A review of the above-mentioned document was conducted by representatives of the Internal Review Committee of NEPA, supported by written comments received from the Mines and Geology Division and the Water Resources Authority and verbal comments received from the Environmental Health Unit. The following comments are being represented to you for your response:

1 DRAINAGE

1.1 COMMENTS

It was the view of the Agency that the area of greatest environmental concern was that of the proximity and health of marine environment to the proposed development. The EIA did outline the fact that the marine environment, particularly its coral and seagrass resources, were in good condition.

These resources are therefore at significant risk, since the geological, topographic and hydrostratigraphic and floral features of the site would facilitate the conveyance of land-based disturbances directly to the marine environment **through the site's drainage systems**. Drainage impacts were therefore viewed by the Agency as being one of the most critical of all of the possible impacts that could be associated with the development.

The Agency is concerned that excessive water transport caused by development-related influences, could result in excessive siltation of the marine environment and excessive fluvial erosion on the property's beaches. The following drainage specific comments therefore apply:

- 1 There is a need for the development of a **full** understanding of pre-development natural drainage on site, including major and minor drainage flood limits and discharge rates (these must be mapped).
- 2 There is a need for the development of a **full** understanding of the post-development influence on existing flood limits / discharge rates (these must be mapped).
- 3 The information obtained from the two points mentioned above must then be used to determine the areas on the development where the specific location of the intervention measures outlined in the EIA are to be positioned.
- 4 There must also be serious considerations given to the use of other drainage mitigation measures, particularly those designed to minimize site water collection, promote retention and slow the movement of runoff.

There were concerns raised by this Agency about development on the hilly, naturally vegetated areas on the southern section of the property.

It is the technical opinion of the Agency that the geology, topography and hydrostratigraphy of the area will render it conducive to slope instability if construction and vegetation removal processes are initiated. Such actions would also promote accelerated run-off to the northern section of the property and to the marine environment. How is this to be addressed?

The above-stated question is being asked particularly in light of comments outlined at the recently held public presentation in Lucea, where mention was made of a golf course being a component of the development (verbatim minutes dated February 2006 pge 32). Such a development has not been examined in the EIA and indeed has not been represented on any of the plans submitted in support of the EIA. If this is a component of the development, then the lack of consideration of this component of the development is a **gross oversight** and one **which will require its own specific review** within the EIA.

All of the mitigations decided on after the review of the comments outlined above must be represented in the form of a comprehensive drainage mitigation plan **which must be submitted to the National Works Agency for approval**. This approval **will be required for incorporation as a condition of the Environmental Permit** that would be issued for the development once an agreement on the outcome of the EIA can be arrived at.

1.2 RESPONSE

In order to minimize the negative effects of stormwater on the marine environment, there is need for careful examination. This has to be done in three phases, namely:

- a) Pre-development natural drainage
- b) Construction period drainage measures
- c) Post development effect on flood condition

The resolution or treatment of the three situations requires the combined efforts of the Environmental Consultants and the Engineering Consultants.

On this basis the mitigation of negative effects related to drainage will be addressed early in the process (during the pre-construction and construction periods) to prepare the site for any eventuality in terms of heavy rainfall that may occur during the development of the hotel. The proposed approach and methodology to accomplish this is presented below.

These are as follows:

- a) Utilize a double French Drain on the Northern side of the main road. This will intercept the stormwater (containing silt) and filter the silt and slow down the flow rate so that scouring will be minimized.

The two French drains would be separated by a membrane such as geo textile. This lining will serve to trap and keep sediments out of the drain. These drains will discharge into the drains on the northern side of the main road.

- b) Utilize a series of sedimentation basins on the northern and southern sides of the main road. Details of the types and sizes of the various compounds will be the subject of the detailed design. In addition, special components (such as baffles) will be included in the sedimentation basins to enhance settling.
- c) Landscape the areas on the hotel lands and any disturbed areas on the uplands (across the street) so as to prevent rapid overland flow of stormwater in the case of a flash flood.
- d) Examine and effectively implement monitoring of the various components of the construction activity so as to ensure that during any rainy season there is very little or no impact on the marine environment.
- e) In order to reduce the amount of stormwater flowing overland to the sea, it is proposed to use a series of gutters to collect the run-off from the top of the buildings and deposit it in the sea without making contact with the ground. This flow will be free of any sediments or nutrients.
- f) It is proposed to create a number of mini drainage basins and examine each in terms of the volume of water to be handled by each then combine them to see the overall effect.

The layout and proposed locations of the mitigation features described above are presented on the attached maps – Figures 1 and 2.

The mention of a golf course in the public meeting was in the context of future and continued development of the property. The golf course was not discussed in the EIA report because it represents a later phase of the development (Phase III) and will be studied and reported on separately if and when a decision is made to move forward with its development. The development of the golf course will ultimately be based on economic, environmental and customer demand for the product.

A copy of the proposed drainage mitigation and associated figures will be submitted to the National Works Agency simultaneously for their review.

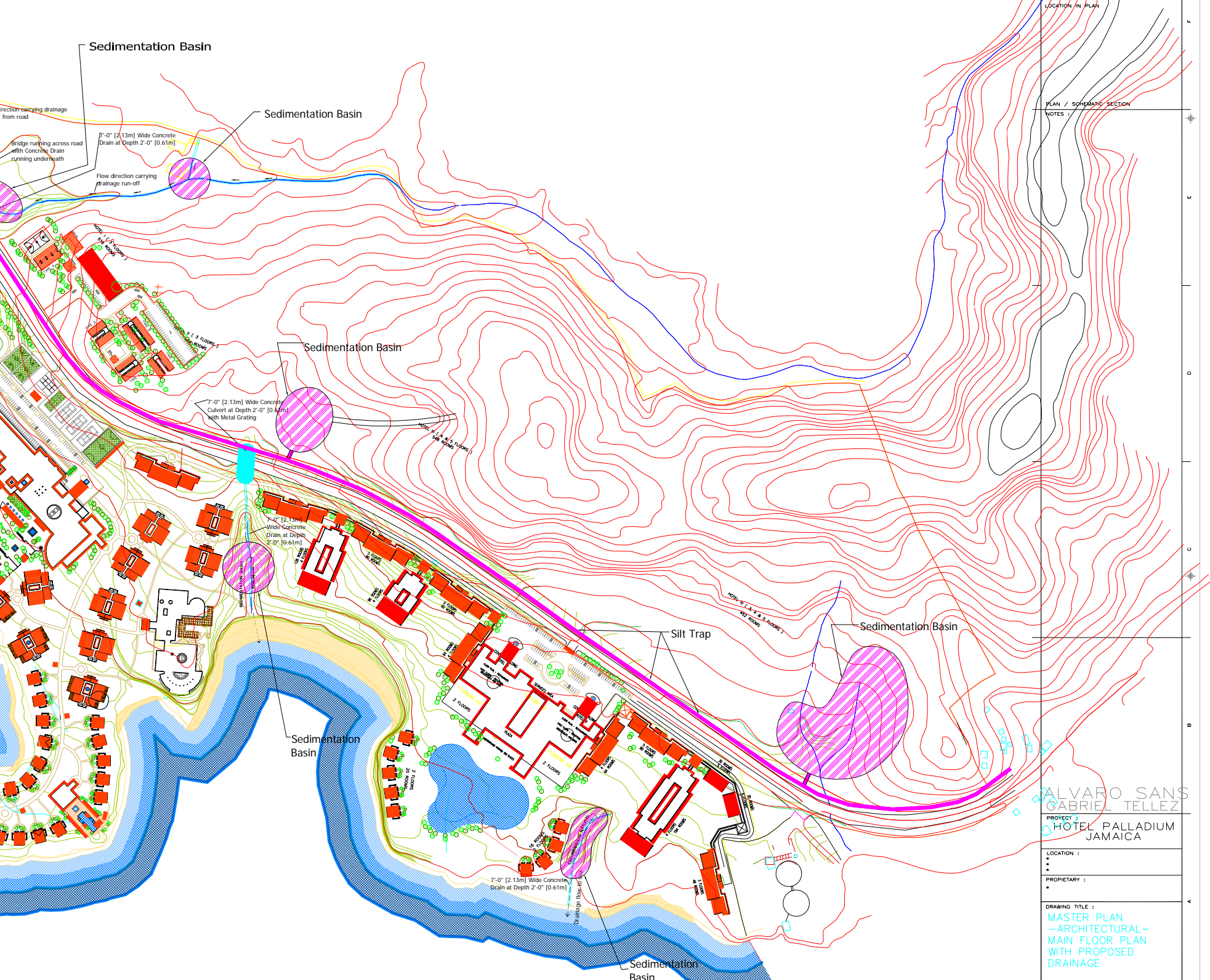

LOCATION IN PLAN

PLAN / SCHEMATIC SECTION

NOTES :

ALVARO SANS
GABRIEL TELLEZ
PROJECT
HOTEL PALLADIUM
JAMAICA

LOCATION :

PROPRIETARY :

DRAWING TITLE :
MASTER PLAN
- ARCHITECTURAL -
MAIN FLOOR PLAN
WITH PROPOSED
DRAINAGE

No.	BY	DATE	CHECK BY:	DESCRIPTION	No.	BY	DATE	CHECK BY:	DESCRIPTION	DATE	COPY FOR :	DATE	DRAWN BY:	APPROVED BY :	DATE	SCALE :	DIMENSIONS :	CM.S.
1	AS	SEP 15 05											AS/GT			1:2000	CMS.	

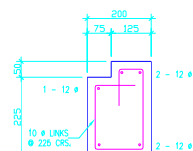
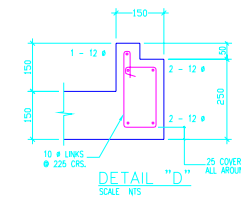
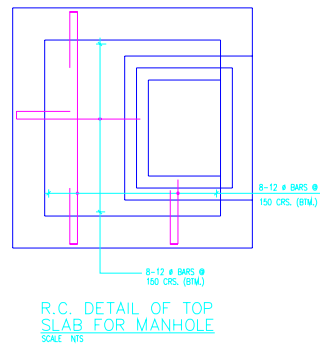
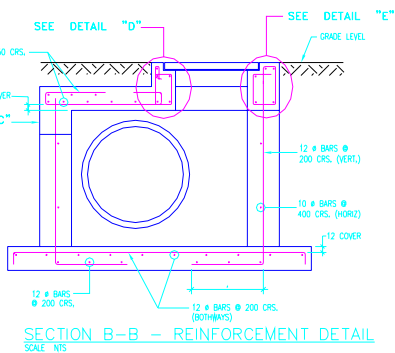
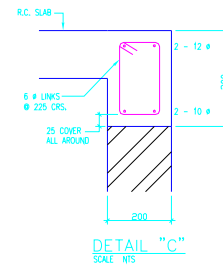
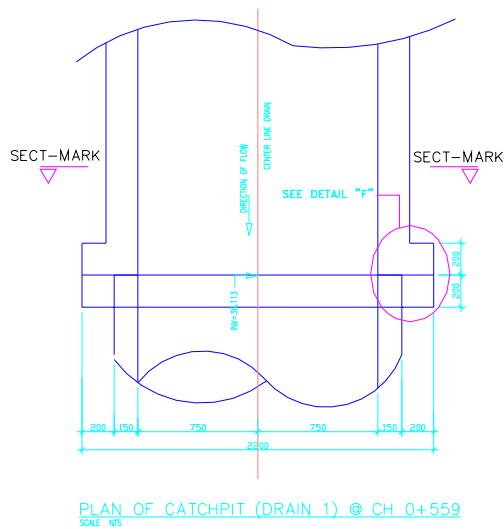
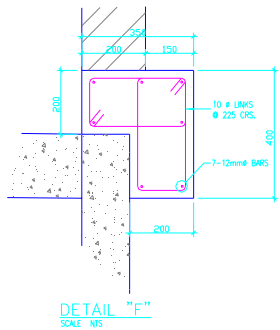
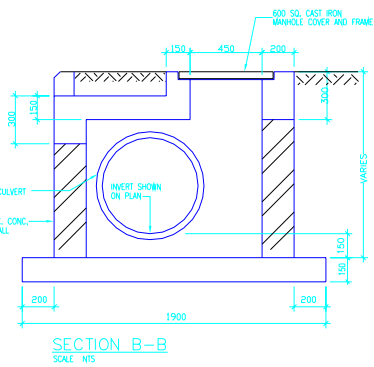
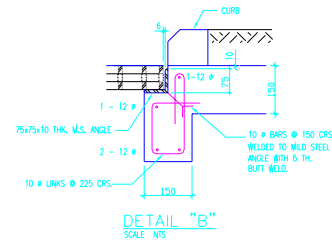
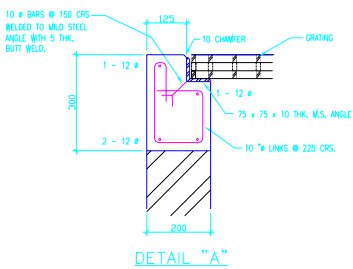
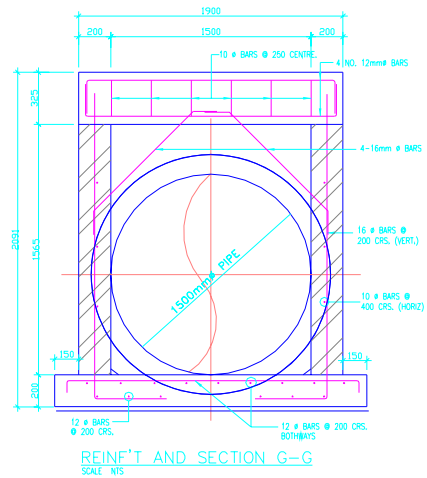
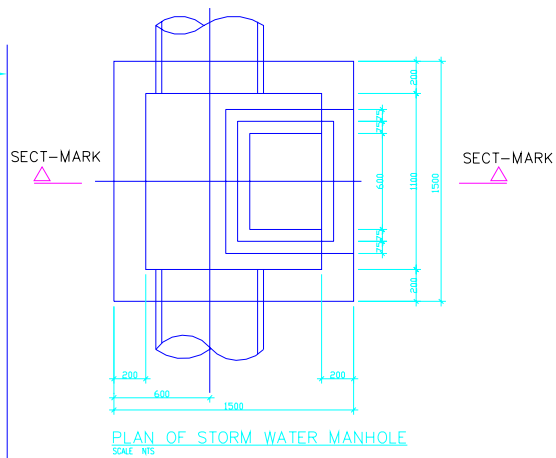

PLAN / SCHEMATIC SECTION

NOTES :

ALVARO SANS
GABRIEL TELLEZ

PROJECT :
HOTEL PALLADIUM
JAMAICA

LOCATION :
PROPRIETARY :

DRAWING TITLE :
DRAINAGE DETAILS 1

SCALE 1 : 15

ER ROADWAY.
N VERGES AND WAYLEAF.
CULVERT PIPE IN ROADWAY IS

2 NUTRIENT CONTAMINATION

2.1 COMMENT

It is recognized that a permit application for the sewage treatment and disposal mechanisms for the development is now in the Agency for review. Nevertheless, the Agency's sewage concerns relate to the opinion that the soil and geological conditions at the site will prevent both irrigation and soil-based sewage disposal options from being effective during protracted periods of rainfall, such as was experienced during Hurricane Wilma in 2005. The soil based disposal options outlined in the EIA do not seem to be a good option if the soil is unable to facilitate percolation due to water-logging.

2.2 RESPONSE

Fiesta has not proposed a soil-based sewage disposal option at any point in its proposals or documentations. What has been proposed is for treated effluent from the sewage treatment plant, meeting Ministry of Health and NEPA irrigation standards to be used for irrigation of plants, etc. on the property. The concern of treated effluent disposal during periods of excessive rains was raised previously and a response was provided in the 'Addendum to the Environmental Impact Assessment' document submitted to NEPA in February 2006. That response provided details of a Tile Field/Emergency Absorption Bed design that would provide for the quick removal of large volumes of treated effluent from the site.

2.3 COMMENT

The EIA alluded to measures to be taken to ensure that phosphate control is assured through Hotel management procedures, to include the use of phosphate free detergents and soaps. It is agreed that since the marine environment is phosphate limited, the reduction of phosphate releases to the marine environment, through sewage discharge, will assure adequate effluent control. What are the policy measures to be adopted by the Hotel management to guarantee phosphate reduction in sewage effluent?

2.4 RESPONSE

All sampling and analysis of treated effluent from the sewage treatment plant that is required by NEPA, Ministry of Health or any other regulatory agency in Jamaica will be done by Fiesta. Protocols will be established and proper record keeping and monitoring will be implemented from the start of operations. If any measured parameter exceeds the discharge limits, the appropriate steps, including notifications to relevant agencies will be undertaken to ensure that the situation is remedied in a timely manner.

2.5 COMMENT

Now that it has been “confirmed” that a golf course will be a part of the overall development planned, this puts an unforeseen nutrient source component into the picture. Information obtained from the operators of the Half Moon and White Witch Golf Courses indicate that fertilizers are applied to the courses, in addition to the nutrients that may reside in the treated effluent used in irrigation. How will marine eutrophication impacts due to the run-off of excess nutrient on the golf course be prevented? Note that this is an issue that plagues the Rose Hall area of St. James (and its concerned Whitehouse Fisherfolk) to this day.

2.6 RESPONSE

A golf course is being considered as a future phase of development at the site. The drainage solutions being incorporated (as indicated earlier in this document) will be sufficient to effectively manage any additional flows and related sediments and/or nutrients that may be generated by the golf course. However, separate studies and determinations will be made if and when a decision is made to develop a golf course at the site. This would include drainage and environmental studies as appropriate.

3 BEACH MODIFICATION

3.1 COMMENT

The EIA’s comments on the matter of beach modification are noted. It is, however, known that at least one of the Beaches (beach 4 numbered from west to east) has waters that are thigh deep at the point where hard bottom colonized by juvenile corals occurs. Frequent patronage will ultimately result in the death of what is obviously an encouraging sign of coral recruitment in the area. How is this to be addressed?

The exact locations and areas of the seagrasses to be removed will have to be indicated on diagrams so that these are clearly identifiable in the field. Additionally, a similar representation will be required for the areas to which these seagrasses will be relocated once removed.

3.2 RESPONSE:

Any benthic areas colonized by juvenile corals will be identified and recognized as no contact zones. That is, no motorized equipment will be allowed in these areas. As a policy measure, it is recommended the Hotel Management formulate strict guidance as it relates to the use of the marine zone, by putting in the necessary mooring buoys in ideal locations, setting up education booths for what is contained in the immediate coastal zone and the dos and don’ts as it relates to the areas, as well as placing educational pamphlets in each room or similar arrangements.

It is recommended that a sign be put in place at ideal locations of the property outlining where corals and seagrass beds are located and their importance to the marine environment.

The seagrass removed will be replanted at an approved location, through NEPA, within the immediate region where recruitment success is guaranteed. This will be done on a 2:1 new area to affected area ratio.

There are seven beaches outlined in the EIA. The following calculations are for maximum seagrass removal using the following assumptions:

1. seagrass covers the full extent of the approximated allowed bathing beach
2. the seaward limit (distance in metres) allowed is 20 m irrespective of depth

The beach face (parallel coastline) and seaward limit for each beach is outlined below:

- Beach 1: 100 m x 20 m
- Beach 2: 100 m x 20 m
- Beach 3: 200 m x 20 m
- Beach 4: 50 m x 20 m
- Beach 5: 130 m x 20 m
- Beach 6: 100 m x 20 m
- Beach 7: 70 m x 20 m

Therefore, the maximum area is estimated at 15,000 square metres (3.7 acres). It should be noted, however, that it is unlikely that this much seagrass will be removed. The growth of seagrass is patchy in some areas along these beaches. The size of each beach face is likely to be less than the estimated value for the smaller beaches. Beaches to the east are more vulnerable to storm surge and wave action and as such are likely to have significantly smaller patches of seagrass than the more sheltered ones to the west of the property.

4 BEACH USE AND PRESCRIPTIVE RIGHTS

4.1 COMMENT

The use of the beaches on the property in the past, particularly beach 3 (numbered from west to east), cannot be disputed. There needs to be a much clearer indication of the measures to be used to ensure that the public's access to beaches in the area is maintained. Will access be maintained to one or more of the beaches on the property? Where will this/these access/accesses be?

4.2 RESPONSE

Fiesta has committed to the cleaning and development of the various beaches on its immediate property and an additional beach located on the eastern property line. The beach on the eastern property line will be open to the public at all times. Access to this beach will be from the main road and will offer clear and unobstructed access to the sea.

5 SHORELINE PROCESSES AND STORM WAVE IMPACTS

5.1 COMMENT

It is agreed that the relative position of the waterline has not shown appreciable change, at least over the last 15 years. The Agency's GIS-based comparative assessment of time sequenced aerial imagery of the location has, however, shown what has been concluded to be erosion of the shoreline edge of the Hanover Formation between Beaches 5-7 (numbered from west to east). The status of shoreline stability in all its aspects therefore needs to be confirmed **through measurements**, since this will have implications for the positioning of buildings and their stability.

Hurricane Ivan has shown (Copacabana and Caribbean Terrace - St. Andrew) that human created obstructions to the movement of storm waves can exacerbate shoreline erosion. The positioning of buildings in relation to the eroding Hanover Formation could therefore result in the exacerbation of said erosion, if wave run-up will advance to these buildings.

The Agency had expected to see a prediction of the wave run-up on the property due to a worst case scenario storm. Hurricane Allen, a category 5 storm passing north of the island, represents such a case. The modeling of the extent of run-up would show where wave/ building interactions could occur and where the current setbacks being used may have to be amended due to this information. Note that the planning setbacks are guides and speak to the use of local oceanographic information as a means of supplementing the guide information.

5.2 RESPONSE

Using the TAOS model, Caribbean Disaster Mitigation Project (CDMP) has produced maximum likely estimates for surge and wave heights throughout the Caribbean basin for 10-, 25-, 50- and 100-year return periods. Estimates were made for each cell in a 30 arcsecond (approx 1km x 1 km) grid, covering the entire Caribbean. These maps are a result of new techniques for modelling storms and estimating the probabilities of storms, developed in part under the patronage of CDMP. This modelling was also done for individual islands using key locations. Four locations were used for Jamaica, of which Montego Bay is the closest to the project site.

The projection of the illustrations is Plate Carrée, a square grid of latitude and longitude. Resolution is 30 arc-seconds. North-South distances are true to scale. East-West distances are stretched 4.6% at 17 degrees North, and stretched 5.8% at 19 degrees North. All model results were calculated using great-circle distances based on the WGS84 datum.

- **SURGES** include astronomical tide and setups from pressure, wind and wave, but not wave runup. Surges over land are shown as elevation above sea level, not water depth.
- **WAVES** are the heights of wave crests above the storm surge level in open water. Shoreline effects do not appear at this resolution.

Waves and surge heights for Montego Bay were reported from the nearest cell offshore.

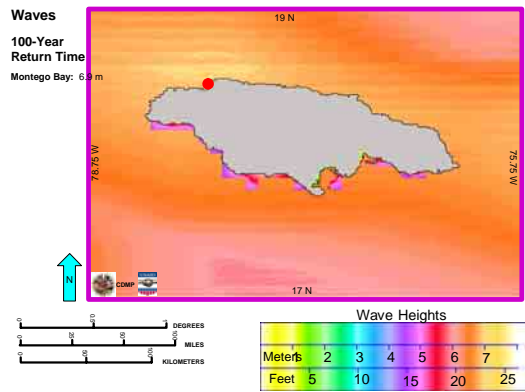
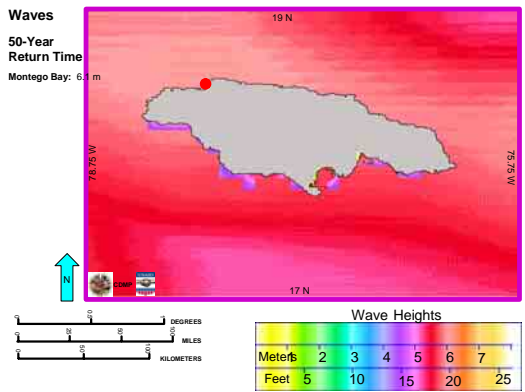
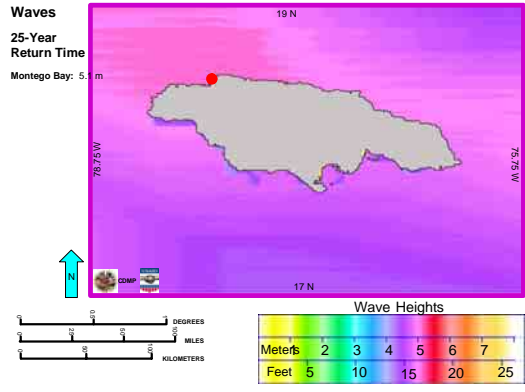
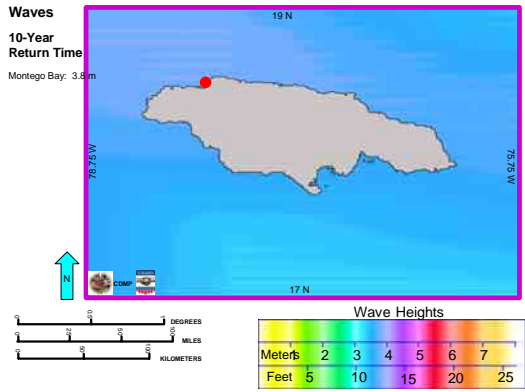

FIGURE 3: 10, 25, 50 AND 100 YEAR RETURN PERIOD FOR WAVE HEIGHTS AT MONTEGO BAY

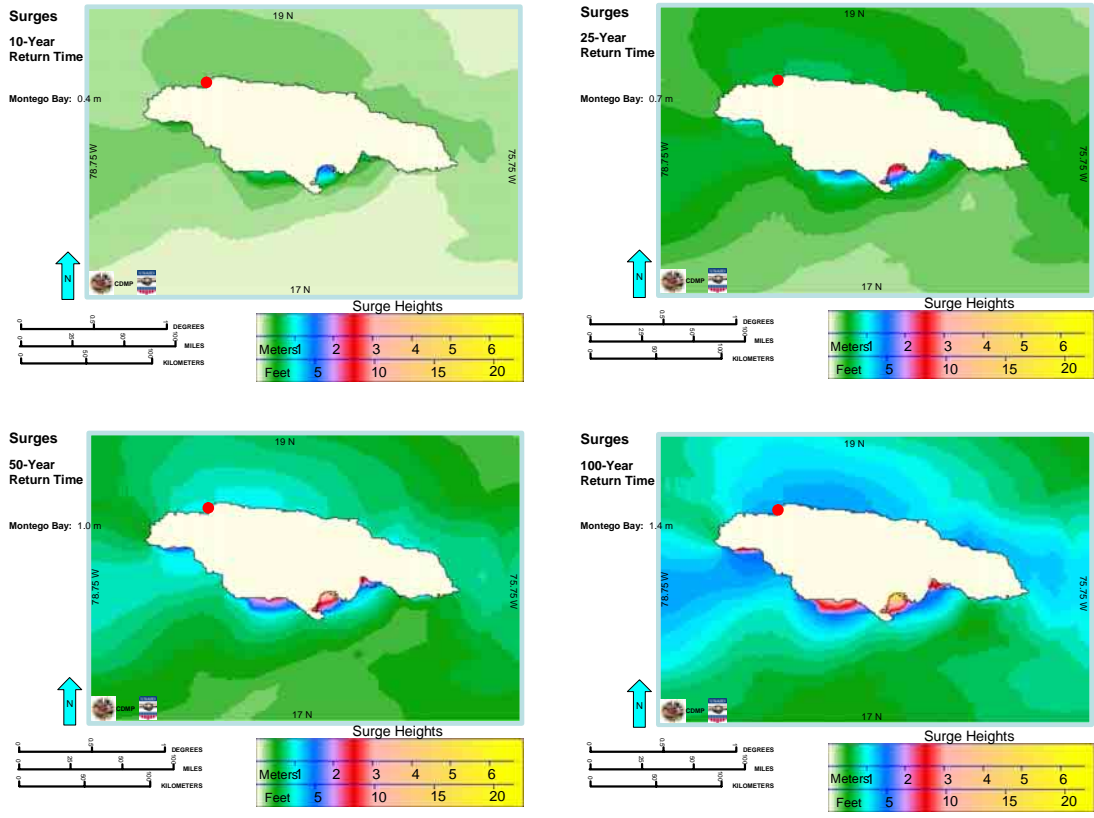

FIGURE 4: 10, 25, 50 AND 100 YEAR RETURN PERIOD FOR SURGE HEIGHTS AT MONTEGO BAY

This data appears to be in line with studies initiated after Hurricane Gilbert in 1988, a Category 3 Hurricane that traversed the length of the country and had significant impact on the north coast. The impact from waves and storm surge was greater since Hurricane Gilbert was a direct hit with sustained winds over a longer period of time, unlike Hurricane Allen that passed at least 30 miles north of the coast and continued moving rapidly in a west by north direction resulting in lower prolonged intensity though more powerful hurricane. This is the only Hurricane to make direct hit to the north coast of Jamaica in the last 15 years. Information from the Caribbean Environment Programme Technical Report #4 1989, indicated the following:

- On the north coast surge level was somewhat higher, apparently reaching about + 2.0 m along the northeastern section. Wave action was apparently most severe on the northeastern section of Jamaica, where wind velocity was highest and the coast most exposed. Fishing beaches reporting heaviest damage were found in Portland, St. Mary and St. Ann. Lesser damage was reported also from Trelawny, St. James and Hanover.¹

¹ Information from the following website, <http://grid2.cr.usgs.gov/cepnet/pubs/techreports/tr04en/Appendix1.htm> accessed March 28, 2006

- One observer thought that storm surge reached about 4 ft on the east and parts of the north coast, but only 3 ft. or less on the south and most of the north coast²
- Generally, the beaches on the North Coast showed severe sand erosion, which exposed roots of trees, piled banks of sand up to 1 m high amidst the vegetation and piled dried and rotting seaweed on the beaches.
- Storm surge varied between 15 m (50 ft) to 106.68 m (350 yds) along the north coast in areas visited. Both erosion and accretion were noted. Memorandum suggests recommending set-back of infrastructures as part of the planning, for future storms.

It is recommended that these figures be used along with the setback guidelines issued by the Parish Council and other Agencies in respect of building setback from the high tide mark.

6 MARINE WILDLIFE INTERACTIONS

6.1 COMMENT

The EIA spoke to signs of turtle nesting being observed on beaches on the property. These beaches were not listed. However, if nesting occurred on one beach, then it is possible that female turtles may have attempted to nest on all of the beaches present within the property. Turtle mitigation measures are therefore required to ensure that any future nesting efforts are not prevented.

While turtle interactions have been mentioned, the EIA has not mentioned that the Lucea harbour and its adjoining seagrass areas are a known habitat for Manatees. The question of seagrass removal to facilitate beach use and its possible impacts on Manatees, who forage within these areas, needs to be addressed.

6.2 RESPONSE:

Turtle nesting was observed on Beach #4 as shown in Figure 1 below. It is accepted that if nesting is observed at one beach it is highly likely it occurs at other beaches on the property or within the region. It is recommended that a Turtle Mitigation Plan be put in place and be incorporated in to the Hotel Managements environmental policy.

As outlined in the Fiesta Addendum Report submitted to NEPA, the following mitigation plan is put forward for the protection of possible turtle nesting beaches at the site.

The proponents will develop materials that will enable visitors and volunteers to distinguish sea turtle species on the basis of nesting crawls, nest sites, eggs, hatchlings, etc. and should be developed with the assistance of the relevant organisations such as NEPA.

² Information courtesy of <http://www.cep.unep.org/pubs/Techreports/tr04en/chapter3.htm> accessed March 28, 2006

- 1) *Artificial lighting:* Sea turtles, especially hatchlings, are profoundly influenced by light. Baby sea turtles, freshly emerged from the nest, depend largely on a visual response to natural seaward light to guide them to the ocean. In zones of coastal development, sources of artificial light distract hatchlings so that they turn away from the sea and crawl landward. It is essential that artificial light sources be positioned so that the source of light is not directly visible from the beach and does not directly illuminate areas of the beach. Low pressure sodium lights should be used to the maximum extent possible. Low intensity, ground-level lighting is encouraged. Night time and security lighting should be mounted not more than 5 m above the ground and should not directly illuminate areas seaward of the line of permanent vegetation. Window shading is recommended.

Natural or artificial structures rising above the ground should be used to the maximum extent possible to prevent lighting from directly illuminating the beach and to buffer noise and conceal human activity from the beach. Planting native or ornamental vegetation, or using hedges and/or privacy fences is recommended.

- 2) *Beach stabilization structures:* The construction of seawalls and jetties, and lights shining on the beach at night should be prohibited or closely evaluated in light of the ecological requirements of endangered turtles.
- 3) *Design setbacks:* Construction setback limits take into consideration beach and backshore characteristics and should be enforced as defined by Jamaica's building codes. Setbacks should provide for vegetated areas between the hotels and the beach proper.
- 4) *Access:* The use of motorized vehicles should be prohibited on all beaches at all times and parking lots and roadways (including any paved or unpaved areas where vehicles will operate) should be positioned so that headlights do not cast light onto the beach at night.
- 5) *Vegetation cover:* All attempts should be made to preserve vegetation above the mean high tide mark. Creeping and standing vegetation stabilizes the beach and offers protection against destructive erosion by wind and waves.
- 6) *Physical destruction of coral and sea grass:* Anchoring should not occur in reef or sea grass areas. Divers, especially tourists, should be thoroughly coached on diving etiquette so as to preclude trampling, collecting, and touching living coral.

This plan can be added to or used as a basis for the protection of coral reef and seagrass beds along the properties coastline.

Regarding the presence or absence of Manatees:

Jamaica's manatees are found mostly along the south coast. They prefer shallow coastal areas such as estuaries, coves and bays where aquatic vegetation is abundant and the water is relatively undisturbed. Most often they can be seen near the mouth of coastal rivers drinking freshwater.

The Lucea Harbour is known to have dense seagrass beds and habitat suitable to manatees through the freshwater inputs of the Lucea East and West Rivers. However, in the Parish of Hanover (to the best of our knowledge) only the Bloody Bay region is known to have had an official siting.

It is in the best interest of the developers to recognize the possibility of the presence of manatees and put in place measures to protect this nationally protected marine animal. This can only be of positive value to the resort and the surrounding community, possibly leading to conservation of the Lucea Harbour and its associated rivers and embayments.

The following basic Manatee Mitigation Plan is therefore put forward.

- Place signs and/or notices indicating that manatees are present in the area and encourage guests and residents of the community to report sightings
- Develop no wake zones along the hotel shoreline to keep boat speeds minimal
- Minimize causes of manatee disturbance, harassment, injury, and mortality;
- Protect, identify, evaluate, and monitor manatee habitats (if identified)
 - **Assess manatee status and distribution with NEPA's assistance**
 - **Identify habitat requirements and protect areas of special significance to manatees**
 - **Promote co-operation and exchange of information on manatee sitings and conservation measures**
- Facilitate manatee recovery through public awareness and education.
 - **Establish an information and co-operation network among the Wider Lucea area and NEPA**
 - **Develop guidelines for manatees and tourism**

Submerged aquatic vegetation (SAV) consists of seagrasses and algae. It is not only a critical component of the ecology of the area, but also forms the largest component of a Manatee's diet. Fortunately, the marine environment in and around the proposed development has significant quantities of seagrasses and algae suitable for manatee consumption.

The above mitigation plan may be supplemented by the one prepared by the Regional Coordinating Unit (RCU) of CEP of the United Nations Environment Programme (UNEP), in co-operation with the Natural Resources Conservation Authority (NRCA) of the Government of Jamaica.



FIGURE 5: BEACH LOCATION AND NUMBER FOR FIESTA HOTEL AT POINT, HANOVER

It is recommended that signs be put in place at ideal locations of the property outlining where corals and seagrass beds are located and their importance to the marine environment.

The seagrass removed will be replanted at an approved location, through NEPA, within the immediate region where recruitment success is guaranteed. This will be done on a 2:1 new area to affected area ratio.

7 TERRESTRIAL WILDLIFE INTERACTIONS

Avi-fauna are the most obvious fauna that would be impacted by vegetation removal from the site. Since these and other faunal types are dependent on foliage for food and shelter, it is then reasonable to believe that a reproduction of the natural vegetation character after the hotel has been implemented would ensure the maintenance of these faunal types. This speaks to a need to accurately represent the landscaping measures to be put in place to ensure this, not only for the Hotel, but also for the proposed golf course.

7.1 RESPONSE

Many of the mature trees such as Guango (*Samanea saman*), Pimento (*Pimenta dioica*), Ackee (*Blighia sapida*), Guinep (*Melicoccus bijugatus*) and Silk Cotton Tree (*Ceiba pentandra*) etc found on the property will be retained on the property. Through landscaping, new trees and vegetation will be introduced that will provide food and habitat for avi-fauna and other wildlife.

It is also recommended that stands of existing vegetation on the south of the property be retained as much as possible. If a golf course is developed, it will provide great opportunities for natural vegetation to remain in certain areas. Golf courses typically retain significant areas of natural vegetation to buffer the greens. This will also assist in the water retention capability of the area.

8 SOCIO-ECONOMIC SURVEY RESULTS

8.1 COMMENT

The socio-economic survey concept outlined in the EIA report is a good one. The EIA's socio-economic survey, however, was limited in its geographical extent. Only residents within the areas of eastern and southern Lucea Bay were interviewed. The town of Lucea was, for the most part, ignored. **Not conducting interviews within the Lucea urban area was an oversight.** The development will be clearly visible from the town and will maintain, at minimum, a visual impression on the town for the next decades.

The conducting of the public presentation on the EIA on February 24, 2006 may have compensated for the lack of representation from the Lucea area and ESTECH is being commended for a well put-together set of minutes.

8.2 RESPONSE

In researching the demographics of the area prior to the implementation of the socio-economic survey it was determined that in fact, the Town of Lucea did not support large numbers of households. Rather, the majority of households were found in adjoining communities such as those in which the surveys were conducted. We do believe that the distribution of EIA reports and the keeping of the public meeting in the urban section of Lucea did assist in getting information to the people in that area.